

## پیوست شماره ۶

### مشخصات فنی و اطلاعات تکمیلی

شماره صفحه ۴۹ از ۴۹	<b>سند شرایط و ضوابط مناقصه عمومی یک مرحله‌ای</b> <b>"خرید قطعات برای تکمیل تابلوهای سیستم کنترل واحد" - تجدید شده</b>	
------------------------	---	---

Row	Tag ID.	Unit	Quantity
۱	The ABB TU847 is a Single module termination unit (MTU) for redundant configuration	No	22
۲	The ABB CI840 A Fieldbus Communication Interface (FCI) module	No	30
۳	The ABB TU830V1 MTU can have up to 16 I/O channels and two process voltage connections	No	145
۴	The ABB AI845 Analog Input Module for single or redundant applications $\wedge$ channels for 0...20 mA, 4...20 mA, 0...5 Vdc	No	10
۵	The ABB AO845/AO845A Analog Output Module for single or redundant $\wedge$ channels of 4...20 mA outputs	No	5
۶	The ABB DI810 module has 16 digital inputs. The input voltage range is 18 to 30 Vdc	No	30
۷	The ABB DO810 module has 16 digital outputs. The output voltage range is 10 to 30 volt and the maximum continuous output current is 0.5 A	No	30
۸	PHOENIX SUBCON-PLUS-PROFIBUS-D-SUB / Order : 2744348	No	50
۹	STAHL Isolator Barriers SMART Transmitter Power Supply Order: 9160/23-10-10S	No.	400
۱۰	STAHL Isolator Barriers SMART Transmitter Power Supply Order: 9165/16-11-11S	No	350
۱۱	STAHL Isolator Barriers SMART Transmitter Power Supply Order: 9170/21-11-11S	No.	400
۱۲	STAHL Isolator Barriers SMART Transmitter Power Supply Order: 9175/20-16-11S	No.	200
۱۳	STAHL Isolator Barriers pac-Bus single element ISpac Order: 9194/31-17	No.	900
۱۴	STAHL Isolator Barriers pac-Bus terminal set ISpac Order: 9194/50-01	No.	110

### توجه:

(۱) پیشنهاد مالی مناقصه‌گران برای تامین "قطعات تابلوهای سیستم کنترل واحد" باید عیناً مطابق با Order Code های ارائه شده در **جدول بالا** باشد. با توجه به عدم تولید و ویرایش جدید برخی از اقلام مناقصه، Order Code ها در تجدید مناقصه، طبق جدول بالا اصلاح شده‌اند. از این رو در صورت مغایرت Order Code ها در مشخصات تکمیلی ارائه شده در Data Sheet ها (که در ادامه آمده است) با جدول بالا، مناقصه‌گران باید اطلاعات جدول بالا را برای ارائه پیشنهاد های فنی بازرگانی و مالی خود مد نظر قرار دهند.

(۲) مدل ترمینالهای کانکشن و ایرینگ باید به صورت پیچی لحاظ شوند و لازم است برای کلیه بریرها به تعداد محل کانکشن، ترمینال تامین شود.



Reference Data Sheet

No : 1403-1

---

## TU847 Redundant MTU for CI840, single ModuleBus

### Features

- Power supply connection.
- Two PROFIBUS connections.
- Two service tool connections.
- Two rotary switch for station address setting.
- ModuleBus connections.
- Connector for ModuleBus Optical Port.
- Mechanical keying prevents insertion of the wrong module type.
- Latching device to DIN rail for locking and grounding.
- DIN rail mounted.

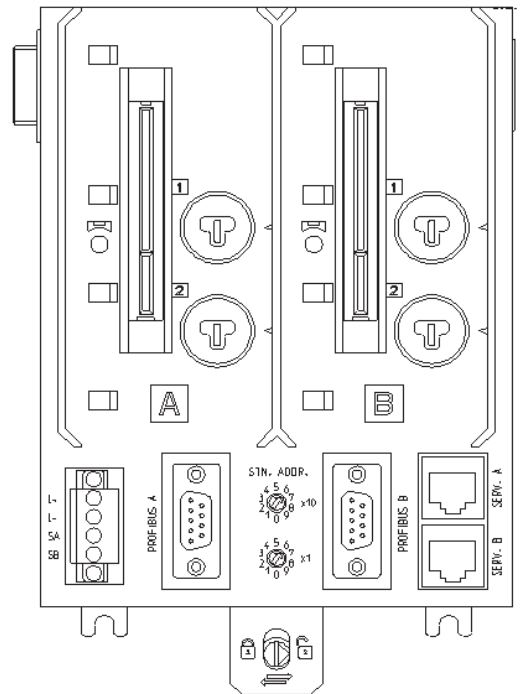

### Description

The TU847 is a module termination unit (MTU) for redundant configuration of the field communication interface CI840.

The MTU is a passive unit having connections for power supply, electrical ModuleBus, two CI840 and two rotary switches for station address (0 to 99) settings.

A ModuleBus Optical Port TB842 can be connected to TU847 via TB806.

Four mechanical keys, two for each position, are used to configured the MTU for the right types of modules. Each key has six positions, which gives a total number of 36 different configurations. The configurations can be changed with a screwdriver.

---

---

The MTU can be mounted on a standard DIN rail. It has a mechanical latch that locks the MTU to the DIN rail. The latch can be locked/unlocked with a screwdriver.

The MTU has two BLOCK signals, one for each module position, that keeps the modules in its init state until it is locked in its position.

## Technical Data

### *TB847 Redundant MTU for CI840*

Item	Value
Power input	24 V d.c. (19.2 - 30 V)
PROFIBUS connection	DSUB9 connector
Service ports	RJ45 connector
ModuleBus current distribution Maximum 5 V Maximum 24 V	1.5 A 1.5 A
Mechanical keys (2)	36 different combinations
Safety Classification	Class I according to IEC 536; (earth protected)
Protection Rating	IP20 according to IEC 529, (IEC 144)
Rated insulation voltage	50 V
Dielectric test voltage	500 V a.c.
Width	124 mm (4.88")
Acceptable wire sizes	0.25 - 2.5mm <sup>2</sup> , 24 - 14 AWG Recommended torque: 0.5 - 0.6 Nm Stripping length: 6-7.5 mm, 0.24-0.30 in
Depth	47 mm (1.85")

---

*TB847 Redundant MTU for CI840 (Continued)*

Item	Value
Height	186 mm (7.32") including latch
Weight	0.5 kg (1.1 lbs.)

**Dimensions**

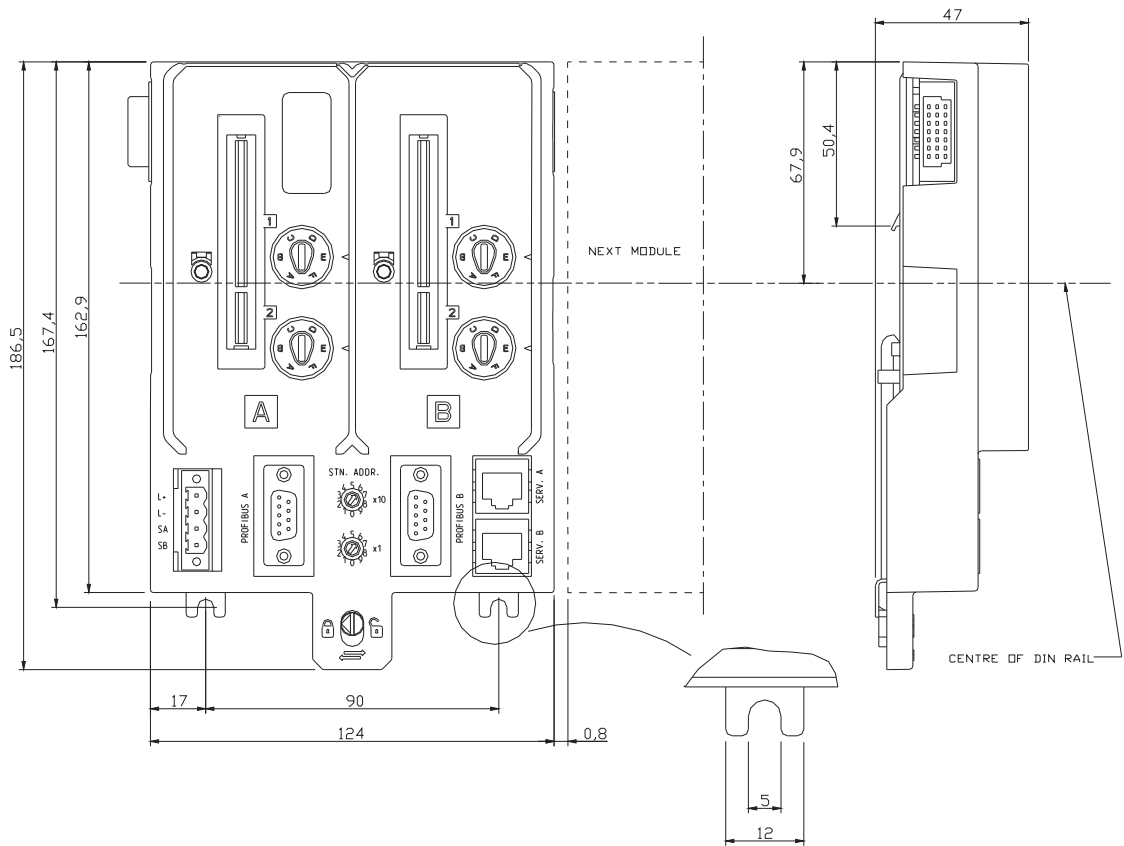

*Dimensions TU847*

---

## Connections

### *TU847 Power Supply Connections*

Designation	Description
L+	+24 V d.c. Supply In
L-	0 V d.c. Supply In
SA	Redundant Power Supply "A" Monitoring Input
SB	Redundant Power Supply "B" Monitoring Input

### *PROFIBUS Connector Pin-out*

Pin	Designation	Description
1	Shield	Shield/protective ground
2	NC	Not used
3	RxD/TxD-P	Receive data/transmit data positive
4	RTS	Direction control (optional)
5	DGND	Data ground
6	VP	Supply of termination resistance (5V)
7	NC	Not used
8	RxD/TxD-N	Receive data/transmit data negative
9	DGND	Data ground (if RTS is used)

### *Service Port Connector Pin-out*

Pin	Designation	Description
1	NC	Not used
2	NC	Not used
3	Tx	Transmitted data

---

---

*Service Port Connector Pin-out (Continued)*

<b>Pin</b>	<b>Designation</b>	<b>Description</b>
4	GND	Signal ground
5	GND	Signal ground
6	Rx	Receive data
7	NC	Not used
8	NC	Not used

---



Reference Data Sheet

No : 1403-2

---

## CI840 Fieldbus Communications Interface (FCI)

### Features

- PROFIBUS-DPV1 fieldbus interface.
- Supervisory functions of I/O ModuleBus.
- Isolated power supply to I/O modules.
- OSP handling and configuration.
- Input power fused.
- Hot Configuration In Run.
- HART pass-through.

### Description

The CI840 Fieldbus Communications Interface (FCI) is an intelligent communication interface between a Controller via the PROFIBUS-DPV1 fieldbus and the S800 I/O modules via the ModuleBus.

CI840 is designed to be used in redundant applications.

CI840 contains one PROFIBUS-DPV1 interface, two electrical ModuleBus interfaces, LED indicators and a opto-isolated RS232 service port.

CI840 has isolated power converters that generates internal power for CI840 and current limited +5 V supply for two electrical ModuleBuses.

Besides +5 V CI840 also distribute a current limited 24 V for the two ModuleBuses.

CI840 must be mounted on a Module Termination Unit TU846 or TU847. With CI840 mounted on a TU847, only one electrical ModuleBus is connected. When mounted on a TU846, two electrical ModuleBuses are connected.

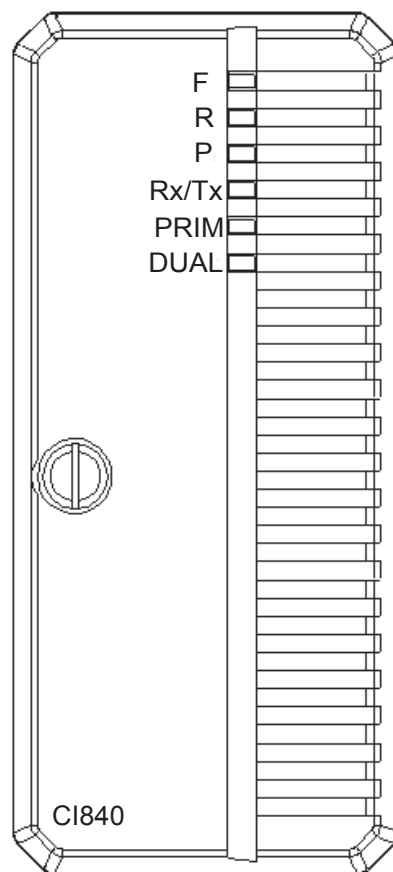

CI840

---



---

The Module Termination unit is DIN-rail mounted and grounded to the DIN-rail. The Module Termination Unit TU847 carries screw terminals for power supply and redundant power supply monitoring, two D-way terminals for PROFIBUS, two connectors for the service ports, one connector for the Optical ModuleBus Port TB842, mounted on TB806, and one electrical ModuleBus.

The Module Termination Unit TU846 carries screw terminals for power supply and redundant power supply monitoring, two D-way terminals for PROFIBUS, two connectors for the service ports, two connectors for the Optical ModuleBus Port TB842, mounted on TB846, and two electrical ModuleBuses.

---

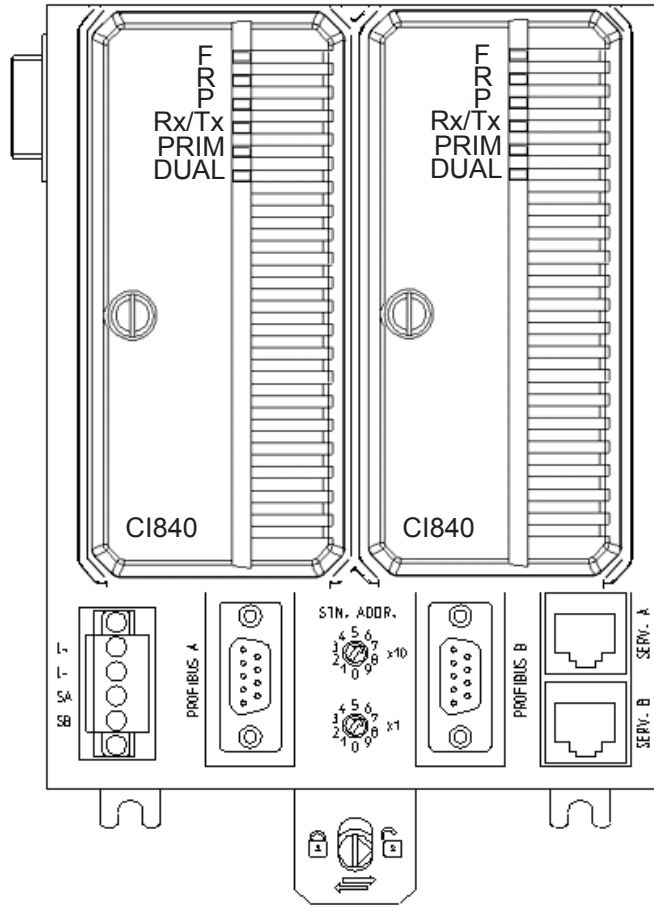

*CI840 and TU847*

---

## Technical Data

### *CI840 FCI Specification*

<b>Item</b>	<b>Description</b>
Microprocessor (CPU)	Motorola MCF5307 with a speed of 64 MHz
Flash PROM	1 Mbyte
Fast RAM	8 Mbyte
Power Input	24 V d.c. (19.2 - 30)
Power Input Fuse	2 AF
Power Consumption at 24 V d.c.	190 mA
Power Dissipation	7.7 W
Maximum Ambient Temperature	55°C (131°F) horizontal mounted 40°C (104°F) vertical mounted
Power Supply Monitoring Inputs	Max. input voltage: 30 V Min. input voltage for high level: 15 V Max. input voltage for low level: 8 V
Service Port (RJ 45 connector on TU847)	Opto-isolated (RS-232); 19.2 Kbaud/s maximum
PROFIBUS (D-sub 9-pole female socket)	Opto-isolated (RS-485); 12 Mbit/s maximum
ModuleBus	Maximum of 12 I/O modules
Power Output - ModuleBus	24 V max. = 1.4 A 5 V max. = 1.5 A Current limited
Switch over time at failure in a redundant CI840 unit	Typical <100 ms Maximum 150 ms

---

---

*CI840 FCI Specification (Continued)*

<b>Item</b>	<b>Description</b>
Switch over time at communication error on Profibus used by primary CI840	Typical < Watchdog Time <sup>(1)</sup> + 50ms + (6 * Profibus cycle time)
Time to OSP in case of communication error on Profibus	Single FCI: Watchdog Time <sup>(1)</sup> + (2 * Modulebus cycle time) Redundant FCI: Watchdog Time <sup>(1)</sup> + Output Hold Time + (2 * Modulebus cycle time)
MTU Keying code	AA
Safety classification	Class I according to IEC 536; (earth protected)
Protection rating	IP20 according to IEC 529, (IEC 144)
Rated insulation voltage	50 V
Dielectric test voltage	500 V a.c.
Acceptable wire sizes	0.25 - 2.5mm <sup>2</sup> , 24 - 14AWG, Recommended torque: 0.5 - 0.6 Nm Stripping length: 6 - 7.5 mm, 0.24 - 0.30 in
Width	54 mm (2.13")
Depth	96 mm (3.78")
Height	119 mm (4.69")
Weight	0.2 kg (0.44 lb.)

(1) Watchdog Time is set by the Profibus master.

---



## Reference Data Sheet

No : 1403-3

## TU830/TU830V1 Extended MTU

### Features

- 50 Volt applications - use with AI810, AI815, AI820, AI830, AI830A, AI835, AI835A, AI843, AI845, AO810, AO810V2, AO815, AO820, AO845, AO845A, DI810, DI811, DI814, DI830, DI831, DI840, DI880, DI885, DO810, DO814, DO815, DO840, DO880, DP820 and DP840 I/O modules.
- Complete installation of I/O modules using 3-wire connections, fuses and field power distribution.
- Up to 16 channels of field signals and process power connections.
- Connections to ModuleBus and I/O modules.
- Mechanical keying prevents insertion of the wrong I/O module.
- Latching device to DIN rail for grounding.
- DIN rail mounting.

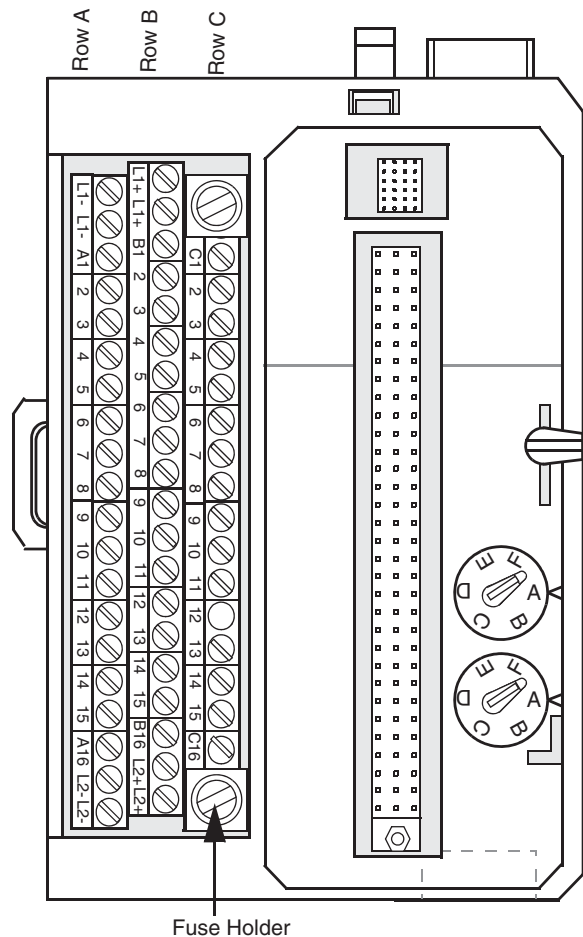

---

## Description

The TU830/TU830V1 is a 16 channel 50 V extended module termination unit (MTU) for the S800 I/O. The MTU is a passive unit used for connection of the field wiring to the I/O modules. It also contains a part of the ModuleBus.

The TU830/TU830V1 MTU can have up to 16 I/O channels and two process voltage connections. Each channel has two I/O connections and one ZP connection.

The process voltage can be connected to two individually isolated groups. Each group has a 6.3 A fuse. The maximum rated voltage is 50 V and maximum rated current is 2 A per channel. It is recommended that the fuse rating be chosen to meet the applications needs.

### *Recommended fuse for TU830*

Module Type	Configuration <sup>(1)</sup>	Total current consumption at 24V process power supply (both groups UP1 and UP2)	Recommended fuse <sup>(2)</sup> per group (L1 and L2)
DO810	NA	Depends on load	Total load one group (8 ch) + 2A
DO814	NA	Depends on load	Total load one group (8 ch) + 2A
DO815	NA	Depends on load	Total load one group (4 ch) + 2A
DO818	NA	Depends on load	
DO840	NA	Depends on load	Total load one group (8 ch) + 2A
DO880	NA	Depends on load	Total load one group (8 ch) + 2A
DI810	2-wire connection	144 mA (9mA per ch @ 30V)	125mA
DI811	2-wire connection	96 mA (6mA per ch @ 60V)	80mA
DI814	2-wire connection	144 mA (9mA per ch @ 30V)	125mA

---

*Recommended fuse for TU830 (Continued)*

<b>Module Type</b>	<b>Configuration<sup>(1)</sup></b>	<b>Total current consumption at 24V process power supply (both groups UP1 and UP2)</b>	<b>Recommended fuse<sup>(2)</sup> per group (L1 and L2)</b>
DI818	2-wire connection		
DI830	2-wire connection	144 mA (9mA per ch @ 30V)	125mA
DI831	2-wire connection	100 mA (6.25mA per ch @ 30V)	80mA
DI840	2-wire connection	159 mA (internal + 9mA per ch @ 30V)	250mA (L1)
DI880	2-wire connection	175 mA (internal 10mA per ch @ 30V)	315mA (L1)
DI885	2-wire connection	32 mA (4mA per ch @ 30V)	63mA (L1 for 24 V, L2 for 48 V)
AO810/AO810V2	NA	245 mA	400mA (L1 or L2)
AO815	NA	218 mA	400mA (L1)
AO820	NA	<sup>(3)</sup>	NA
AO845/AO845A	NA	218 mA	400mA (L1)
AI810	2-wire connection	184 mA (23mA per ch)	160mA
AI815	2-wire connection	265 mA (internal + 23mA per ch)	200mA
AI820	2-wire connection	92 mA (23mA per ch)	80mA
AI830/AI830A	2-wire connection	<sup>(3)</sup>	NA
AI835/AI835A	2-wire connection	<sup>(3)</sup>	NA
AI843	2-wire connection	<sup>(3)</sup>	NA
AI845	2-wire connection	265 mA (internal + 23mA per ch)	200mA

---

*Recommended fuse for TU830 (Continued)*

<b>Module Type</b>	<b>Configuration<sup>(1)</sup></b>	<b>Total current consumption at 24V process power supply (both groups UP1 and UP2)</b>	<b>Recommended fuse<sup>(2)</sup> per group (L1 and L2)</b>
DP820	NA	Depends on load	Depends on load
DP840	2-wire connection, NAMUR	122 mA (internal + 8.2mA per ch @ 8.2V)	200 mA (L1)
DP840	2-wire connection, 12 V	124 mA (internal + 4.3mA per ch @ 12V)	200mA (L1)
DP840	2-wire connection, 24 V	145 mA (internal + 4mA per ch @ 24V)	250mA (L1)

(1) If 3-wire field devices are connected, the internal current consumption must be considered.

(2) Use fuse 5 x 20 mm, Time-Lag.

(3) Unit does not use process power supply.

The MTU distributes the ModuleBus to the I/O module and to the next MTU. It also generates the correct address to the I/O module by shifting the outgoing position signals to the next MTU.

The MTU can be mounted on a standard DIN rail. It has a mechanical latch that locks the MTU to the DIN rail. The latch can be released with a screwdriver.

Two mechanical keys are used to configure the MTU for different types of I/O modules. This is only a mechanical configuration and it does not affect the functionality of the MTU or the I/O module. Each key has six positions, which gives a total number of 36 different configurations. The configuration can be changed with a screwdriver.

The MTU has a mechanical locking mechanism that locks the module in its position. This mechanism also gives the signal BLOCK to the I/O module that keeps the module in its init state until it is locked in its position.

The process signal terminals are divided into 2 equal and individually isolated groups. Each group consists of 8 I/O channels, process voltage connection and a 6.3 A fuse (as delivered). Each I/O channel has two I/O connections and one ZP connection. For input modules, field power is provided by the B-row.

---



---

## Technical Data

### *TU830/TU830V1 Extended MTU Specifications*

Item	Value
Process Connections	56 up to 16 I/O channels (2 terminals per channel) 4 Process power 6.3 A 10 x 2 Process power (0 V)
Rated maximum continuous current per I/O channel	2 A
Rated maximum continuous current per process voltage connection (L+)	5 A
ModuleBus: Maximum 5 V current distribution Maximum 24 V current distribution	1.5 A 1.5 A
Fuse (2)	6.3 A (slow glass tube, 5x20 mm)
Acceptable wire sizes	Solid: 0.2 - 4 mm <sup>2</sup> Stranded: 0.2 - 2.5 mm <sup>2</sup> , 24 - 12 AWG Recommended torque: 0.5 - 0.6 Nm Stripping length: 7 mm
Mechanical keys (2)	36 different combinations
I/O module lock	Locks module and enables operation
Equipment class	Class I according to IEC 61140; (earth protected)
Protection rating	IP20 according to IEC 60529
Rated insulation voltage	50 V
Dielectric test voltage	500 V a.c.
Width	126 mm (5") including connector, 120.5 mm (4.74") edge to edge installed

---

---

*TU830/TU830V1 Extended MTU Specifications (Continued)*

<b>Item</b>	<b>Value</b>
Depth	64 mm (2.52") including terminals
Height	110 mm (4.3")
Weight	0.28 kg (0.6 lbs.)

**Connections**

*TU830/TU830V1 Process Connection Screw Terminals (X1)*

<b>Position (1)</b>	<b>Row A</b>	<b>Row B</b>	<b>Row C</b>
1	L1-	L1+	NC
2	L1-	L1+	NC
3	A1	B1	C1
4	2	2	2
5	3	3	3
6	4	4	4
7	5	5	5
8	6	6	6
9	7	7	7
10	8	8	8
11	9	9	9
12	10	10	10
13	11	11	11
14	12	12	12
15	13	13	13

---

---

*TU830/TU830V1 Process Connection Screw Terminals (X1) (Continued)*

<b>Position <sup>(1)</sup></b>	<b>Row A</b>	<b>Row B</b>	<b>Row C</b>
16	14	14	14
17	15	15	15
18	A16	B16	C16
19	L2-	L2+	NC
20	L2-	L2+	NC

(1) All positions marked NC are not mounted in the connector.

---



Reference Data Sheet

No : 1403-4

---

## AI845 Analog Input Module, single or redundant

### Features

- 8 channels for 0...20 mA, 4...20 mA, 0...5 V or 1...5 V d.c., single ended unipolar inputs.
- Single or redundant operation.
- 1 group of 8 channels isolated from ground.
- 12 Bit resolution.
- Current limited transmitter supply per channel.
- Advanced on-board diagnostics.
- HART pass-through communication.

### Description

The AI845 Analog Input Module for single or redundant applications. The module has 8 channels. Each channel can be either a voltage or current input when MTU TU844 or TU845 is used, when other MTUs are used all channels become voltage or current inputs.

The voltage and current input is able to withstand an overvoltage or undervoltage of at least 11 V d.c. The input resistance for voltage input is greater than 10 M ohm and the input resistance for current input is 250 ohm.

The module distributes the external HART compatible transmitter supply to each channel. This adds a simple connection to distribute the supply to 2-wire or 3-wire transmitters. The transmitter power is supervised and current limited.

If an external power supply is used for feeding HART transmitters, the power supply must be HART compatible.

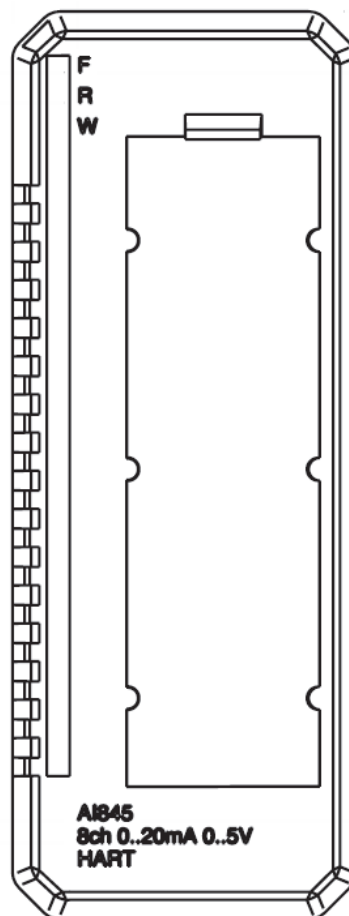

AI845  
8ch 0..20mA 0..5V  
HART

---

The module performs self-diagnostics cyclically. Module diagnostics include:

- External power supply, Transmitter power and External shunt error. Error in these are reported as External channel error.
- Low Pass Filter, Multiplexer and Test channels. Error in these are reported as Internal channel error.
- Analog Read Back, Reference Voltage, Internal Power Supply, Checksum, Watchdog and Memory. Error in these are reported as Module Error.

All eight channels are isolated from the ModuleBus in one group. Power to the input stages is converted from the 24 V on the ModuleBus.

The module has HART pass-through functionality. Only point-to-point communication is supported.

Eight different types of MTUs can be used for single applications. The TU830/TU833 Extended MTU enables three wire connection to the devices without additional terminals. The TU810 (or TU814) Compact MTU has terminals for 24 V process voltage inputs, but requires external terminals for distribution of 24 V power supply to the field devices. The extended MTU, TU835, and TU838 provides a fuse (3 A max.) per channel for process power out. The TU812 Compact MTU has a D-Sub 25 pin (male) connector for connection to the process. The TU818 Compact MTU provides connection to 2-wire sensors without external marshaling.

Three types of MTUs can be used for redundant applications, two for mounting on a horizontal DIN rail and one for mounting on a vertical DIN rail.

Shielded field cables for process connections are required if HART is used.

The parameter Shunt mode should be set to External shunt when the MTU TU844/TU845/TU854 is used or when voltage inputs is required for other MTU.

It is only possible to mix voltage and current input when TU844/TU845/TU854 is used; for other MTUs, all channels become voltage or current inputs.

---

---

## Technical Data

### *AI845 Analog Input Module Specifications at 25° C*

<b>Feature</b>	<b>AI845 Analog Input Module</b>
Number of channels	8
Type of input	Unipolar single ended
Measurement range	0...20 mA, 0...5 V, 4... 20 mA, 1... 5V
Over range	+15%
Input impedance (at voltage input)	10 MΩ
Input impedance (at current input) (including PTC)	250 Ω
Maximum field cable length	600 meters, (656 yd.)
Voltage input, maximum non-destructive	11 V d.c.
NMRR, 50 Hz, 60 Hz	>40 dB
Error	Max. 0.1%
Resolution	12 bit
Temperature drift	Max. 50 ppm/° C
Update cycle time	10 ms
Current consumption 24 V (Modulebus)	50 mA
Current consumption 5 V (Modulebus)	100 mA
Current consumption 24 V (process power supply, UPx)	339 mA (max) (22 mA + transmitter current*1.32)

---

---

*AI845 Analog Input Module Specifications at 25° C (Continued)*

<b>Feature</b>	<b>AI845 Analog Input Module</b>
Power dissipation	3.5 W
Transmitter supply (per channel):	+ - 10% <sup>(1)</sup> HART compatible Voltage: 24 V @ 23 mA Current: 30 mA
Supervision	Module error if: analog read back, reference voltage, internal power supply, checksum, watchdog and memory error Internal channel error if: low pass filter, multiplexer and test channels error External channel error if: external power supply low, transmitter power and external shunt error
Input filter (rise time 0-90%)	290 ms
Isolation	Groupwise isolated from ground
Module termination units	TU810, TU812, TU814, TU818, TU830, TU833, TU835, TU838, TU844 or TU845 and TU854
MTU keying code	CC
Rated insulation voltage	50 V
Dielectric test voltage	500 V a.c.

(1) If the transmitter need more current to start up, use external power for the transmitter.

---



Reference Data Sheet

No : 1403-5

---

## AO845/AO845A Analog Output Module, Single or Redundant

### Features

- 8 channels of 4...20 mA outputs.
- For single or redundant applications.
- OSP sets outputs to predetermined state upon error detection.
- 1 group of 8 channels isolated from ground.
- Analog Output is to be short circuit secured to ZP or +24 V.
- Advanced on-board diagnostics.
- 12 bit resolution.
- HART pass-through communication.

### Description

The AO845/AO845A Analog Output Module for single or redundant applications has 8 unipolar analog output channels.

The module performs self-diagnostic cyclically. Module diagnostics include:

- External Channel Error is reported (only reported on active channels) if the process power supply that supply voltage to output circuitry is too low, or the output current is less than the output set value and the output set value > 1 mA (open circuit).
- Internal Channel Error is reported if the output circuit can not give the right current value. In a redundant pair the module will be commanded to error state by the ModuleBus master.

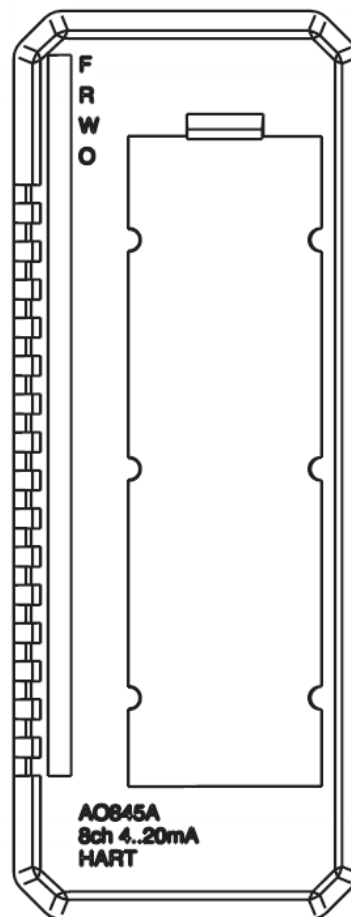



- Module Error is reported in case of Output Transistor Error, Short Circuit, Checksum Error, Internal Power Supply Error, Status Link Error, Watchdog or Wrong OSP behavior.

The module has HART pass-through functionality. Only point to point communication is supported. The output filter must be enabled on channels used for HART communication.

Five different types of MTUs can be used for single applications. The TU830/TU833 Extended MTU and the TU810 (or TU814) Compact MTU enables wire connection to the devices without additional terminals. The TU812 Compact MTU has a D-Sub 25 pin (male) connector for connection to the process.

For redundant applications there are three types of MTUs, TU842/TU852 for mounting on a horizontal DIN rail and TU843 for mounting on a vertical DIN rail.

Shielded field cables for process connections are required if HART is used.

### Technical Data

#### *AO845/AO845A Analog Output Module Specifications at 25°C*

Feature	AO845/AO845A Analog Output Module
Number of channels	8
Output range	4...20 mA
Over range	±15%
Output load	Max 750 ohms
Maximum field cable length	600 meters (656 yd.)
Rise time output filter - disable - enable	23 ms (0-90%) max 4 mA / 12.5 ms
Cycle time	10 ms
Error	Max. 0.1%
Resolution	12 bit

---

*AO845/AO845A Analog Output Module Specifications at 25°C (Continued)*

<b>Feature</b>	<b>AO845/AO845A Analog Output Module</b>
Output Set as Predetermined (OSP) timer	256, 512, 1024 ms
Temperature drift	Max. 50 ppm/°C
Current consumption 24 V (process power supply, UPx)	218 mA (max 20mA on 8 channels)
Current consumption 5 V (Modulebus)	125 mA (max)
Power dissipation <sup>(1)</sup>	3.5 W
Isolation	Groupwise isolated from ground
Mounting termination units	TU810, TU812, TU814, TU830, TU833, TU842, TU843 and TU852
MTU keying code	AO845: CC AO845A: DB
Rated insulation voltage	50 V
Dielectric test voltage	500 V a.c.

(1) 250 ohm load, 70% of nominal current, all channels activated.

---



Reference Data Sheet

No : 1403-6

## DI810 Digital Input Module, 24 V, Current Sinking

### Features

- 16 channels for 24 V d.c. inputs with current sinking.
- Two isolated groups of 8 with voltage supervision.
- Input status indicators.

### Description

The DI810 is a 16 channel 24 V digital input module for the S800 I/O. This module has 16 digital inputs. The input voltage range is 18 to 30 volt d.c. and the input current is 6 mA at 24 V. The inputs are divided into two individually isolated groups with eight channels and one voltage supervision input in each group.

Every input channel consists of current limiting components, EMC protection components, input state indication LED and optical isolation barrier.

The process voltage supervision input give channel error signals if the voltage disappears. The error signal can be read via the ModuleBus.

The input channels can be digitally filtered. The different filter times that can be achieved are 2, 4, 8 and 16 ms. This means that noise pulses shorter than the filter time are filtered out, and pulses longer than 3, 6, 12 and 24 ms get through the filter.

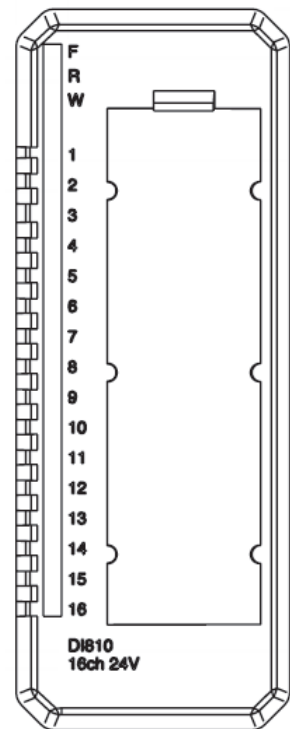

---

Eight different types of MTUs can be used. The TU830/TU833 Extended MTU enables three wire connection to the devices without additional terminals. The TU810 (or TU814) Compact MTU has terminals for 24 V process voltage supervision inputs, but requires external terminals for distribution of 24 V power supply to the devices. The TU818 Compact MTU provides connection to 2-wire sensors without external marshaling. The TU838 extended MTU, provides a fuse (3 A max.) per two channels for process power out. The TU812 Compact MTU has a D-Sub 25 pin (male) connector for connection to the process. TU850 provides one disconnectable PTC fused sensor/transmitter power outlet terminal per channel.

### Technical Data

#### *DI810 Digital Input Module Specifications*

<b>Feature</b>	<b>DI810 Digital Input Module</b>
Number of channels	16 (2 x 8), current sinking
Rated voltage (process power supply range)	24 V d.c. (18 to 30 V d.c.)
Input voltage range, "1"	15 to 30 V
Input voltage range, "0"	-30 to +5 V
Nominal input channel current	6 mA @ 24 V d.c.
Input Current "1"	>3.0mA
Input Current "0"	<1.0mA
Input Impedance	3.5 k $\Omega$
Maximum field cable length	600 meters (656 yd.)
Filter times (digital, selectable)	2, 4, 8, 16 ms
Process voltage supervision	2 channels (1 per group)
Current consumption 5 V (Modulebus)	50 mA
Power dissipation <sup>(1)</sup>	1.8 W

---

---

*DI810 Digital Input Module Specifications (Continued)*

<b>Feature</b>	<b>DI810 Digital Input Module</b>
Isolation	Groupwise isolated from ground
Module termination units	TU810, TU812, TU814, TU830, TU833, TU838 or TU850.
MTU keying code	AA
Rated insulation voltage	50 V
Dielectric test voltage	500 V a.c.

(1) Power dissipation is calculated with 70 percent of the channels activated at nominal voltage of 24 Volts.



Reference Data Sheet

No : 1403-7

---

## DO810 Digital Output Module 24 V, 0.5 A Current Sourcing

### Features

- 16 channels for 24 V d.c. current sourcing outputs.
- 2 isolated groups of 8 channels with process voltage supervision.
- Output status indicators.
- OSP sets outputs to predetermined state upon error detection.
- Short-circuit protection to ground and 30 V.
- Over-voltage and over-temperature protection.

### Description

The DO810 is a 16 channel 24 V digital output module for the S800 I/O. This module has 16 digital outputs. The output voltage range is 10 to 30 volt and the maximum continuous output current is 0.5 A. The outputs are protected against short circuits, over voltage and over temperature. The outputs are divided into two individually isolated groups with eight output channels and one voltage supervision input in each group.

Each output channel consists of a short circuit and over temperature protected high side driver,

EMC protection components, inductive load suppression, output state indication LED and optical isolation barrier.

The process voltage supervision input give channel error signals if the voltage disappears. The error signal can be read through the ModuleBus.

---

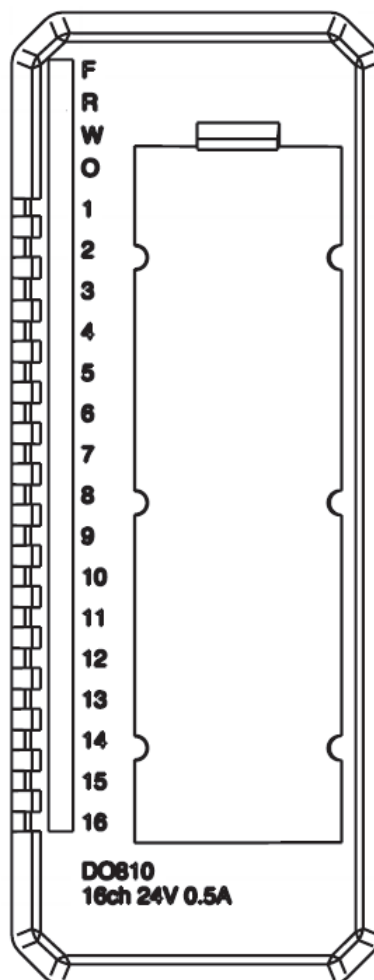

---

The outputs are current limited and protected against over temperature. If the outputs are overloaded the output current will be limited. This means that the power dissipation in the output stage will increase and the output will shutdown if the temperature in the output stage increases above 150° C (302° F). The output will switch on again automatically as the component temperature has decreased to about 140° C (284° F). If any output is shutdown due to overload, the indication LED on that channel is also switched off. The output status of that channel cannot be read from the module.

Four different types of MTUs can be used. TU830 Extended MTU and TU810 (or TU814) Compact MTU have terminals for 24 V output power connections and two terminals per channels. The TU812 Compact MTU has a D-Sub 25 pin (male) connector for connection to the process.

## Technical Data

### *DO810 Digital Output Module Specifications*

<b>Feature</b>	<b>DO810 Digital Output Module</b>
Number of channels	16 (2 x 8)
Type of output	Transistor current sourcing, current limited
Voltage range	12 - 32 V d.c.
Load current, maximum	0.5 A
Short circuit current, maximum	2.4 A
Leakage current, maximum	<10 µa
Output impedance	<0.4 ohm
Maximum Field Cable Length	600 meters (656 yd.)
Current consumption 5 V (Modulebus)	80 mA
Power dissipation <sup>(1)</sup>	2.1 W

---

---

*DO810 Digital Output Module Specifications (Continued)*

<b>Feature</b>	<b>DO810 Digital Output Module</b>
Output Set as Predetermined (OSP) timer	256, 512, 1024 ms
Process voltage supervision	2 channels (1 per group)
Isolation	Groupwise isolated from ground
Mounting termination units	TU810, TU812, TU814 or TU830
MTU keying code	AA
Rated insulation voltage	50 V
Dielectric test voltage	500 V a.c.

(1) Power dissipation is calculated with 70 percent of the channels activated.

---





## Reference Data Sheet

No : 1403-8



D-SUB plug, 9-pos., pin, axial version with two cable entries, below 35°, bus system: PROFIBUS DP up to 12 Mbps, termination resistor can be switched on via slide switch, pin assignment: 3, 5, 6, 8; spring-cage connection terminal blocks



## Key Commercial Data

Packing unit	1 pc
Weight per Piece (excluding packing)	40.0 g
Custom tariff number	85366990
Country of origin	Germany

## Technical data

## Dimensions

Max. cable diameter	8.4 mm
Min. cable diameter	7.6 mm
Width	16 mm
Height	49.5 mm
Length	60 mm

## Ambient conditions

Ambient temperature (operation)	-20 °C ... 75 °C
Ambient temperature (storage/transport)	-25 °C ... 80 °C
Altitude	5000 m (For restrictions see manufacturer's declaration)

## General

Nominal voltage $U_N$	5 V
Nominal current $I_N$	100 mA
Bus system	PROFIBUS DP
Signal	PROFIBUS
Insertion/withdrawal cycles	> 200

SUBCON fixing screws	4-40 UNC
Tightening torque	0.4 Nm
Housing material	ABS, metal-plated
Pin assignment	3, 5, 6, 8
MTTF	6706 Years (SN 29500 standard, temperature 25°C, operating cycle 21 % (5 days a week, 8 hours a day))
	1817 Years (SN 29500 standard, temperature 40 °C, operating cycle 34.25 % (5 days a week, 12 hours a day))
	155 Years (SN 29500 standard, temperature 40°C, operating cycle 100 % (7 days a week, 24 hours a day))

### Connection data

Connection	D-SUB connection
Number of positions	9
Connection method	D-SUB connector
Termination resistor	390 Ω
	220 Ω
	390 Ω (Can be connected externally)
Connection	PCB connection
Connection method	Spring-cage connection
Conductor cross section solid min.	0.12 mm <sup>2</sup>
Conductor cross section solid max.	0.5 mm <sup>2</sup>
Conductor cross section AWG min.	26
Conductor cross section AWG max.	20
Stripping length	5 mm
Tightening torque	0.4 Nm

### Standards and Regulations

Connection in acc. with standard	CUL
ATEX	# II 3 G Ex nA IIC T4 Gc X

### Classifications

#### eCl@ss

eCl@ss 4.0	27140816
eCl@ss 4.1	27140816
eCl@ss 5.0	27143424
eCl@ss 5.1	27143424
eCl@ss 6.0	27143424
	27440209
eCl@ss 8.0	27440302

#### ETIM

ETIM 2.0	EC001132
ETIM 3.0	EC001132
ETIM 4.0	EC001132
ETIM 5.0	EC001132

#### UNSPSC

UNSPSC 6.01	30211802
UNSPSC 7.0901	39121402
UNSPSC 11	39121402
UNSPSC 12.01	39121402
UNSPSC 13.2	39121402

Schematic diagram

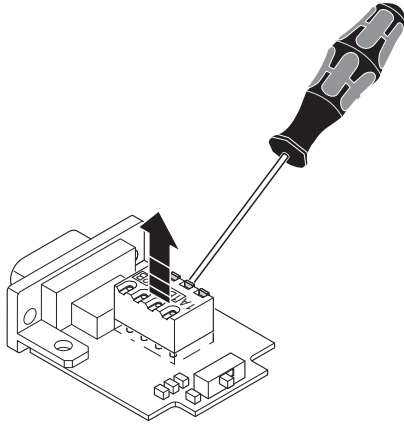

Right-hand side cable entry

Schematic diagram

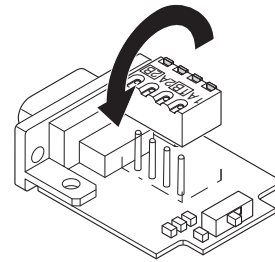

Right-hand side cable entry

Schematic diagram

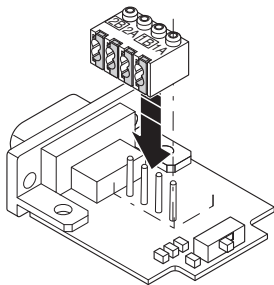

Right-hand side cable entry

Schematic diagram

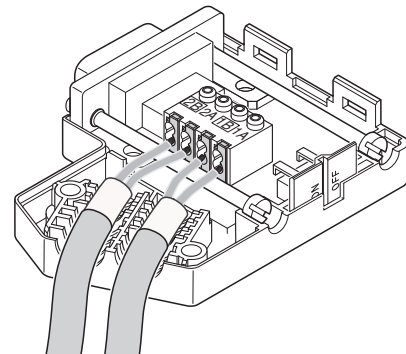

Right-hand side cable entry

Dimensional drawing

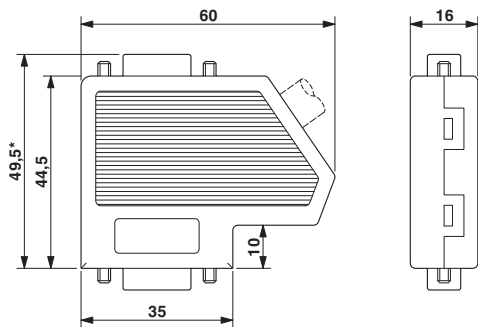

Circuit diagram

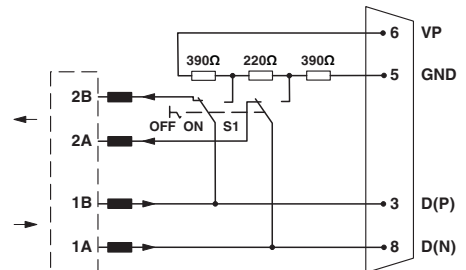

Functional diagram of the connector range SUBCON-PLUS-PROFIB/...



## Reference Data Sheet

No : 1404-1



- Can be used universally for 2- and 3-wire transmitters and mA sources (4-wire transmitters)
- High accuracy
- For use up to SIL 2, special variant up to SIL 3 (IEC/EN 61508)

MY R. STAHL 9160A

HART  
COMMUNICATION PROTOCOL

## Technical Data

## Explosion Protection

Application range (zones)	2
Ex interface zone	0 1 2 20 21 22
IECEX gas certificate	IECEX BVS 08.0050 X
IECEX gas explosion protection	Ex nA [ia Ga] IIC T4 Gc
IECEX dust certificate	IECEX BVS 08.0050 X
IECEX dust explosion protection	[Ex ia Da] IIIC
IECEX firedamp certificate	IECEX BVS 08.0050 X
IECEX firedamp protection	[Ex ia Ma] I
ATEX gas certificate	DMT 03 ATEX E 010 X
ATEX gas explosion protection	⊕ II 3 (1) G Ex nA [ia Ga] IIC T4 Gc
ATEX dust certificate	DMT 03 ATEX E 010 X
ATEX dust explosion protection	⊕ II (1) D [Ex ia Da] IIIC
ATEX firedamp certificate	DMT 03 ATEX E 010 X
ATEX firedamp protection	⊕ I (M1) [Ex ia Ma] I
FMus certificate	FM16US0122X
cFM certificate	FM16CA0067X
Marking cFMus	Class I, Div. 2, Groups A,B,C,D; Class I, Zone 2, nA nC Group IIC AIS Class I,II,III, Div. 1, Groups A,B,C,D,E,F,G; Class I, Zone 0, [Ex ia] IIC T4 Mounting vert. at Ta = 70°C , or horizontal Ta = 60°C See Doc. 91 606 01 31 1

## Explosion Protection

Certificates	ATEX (BVS), Brazil (ULB), Canada (FM), China (NEPSI), IECEx (BVS), Korea (KTL), SIL (exida), USA (FM)
Ship approval	CCS, EU RO MR (DNV)
Declaration of Conformity	ATEX (EUK), China (CCC)

## Safety Data

Max. voltage $U_o$	27 V				
Max. current $I_o$	88 mA				
Max. power $P_o$	576 mW				
Max. permissible external capacity $C_o$ for I	3750 nF				
Max. permissible external inductance $L_o$ for I	40 mH				
Max. permissible external capacity $C_o$ for IIC	0.09 $\mu$ F				
Max. permissible external capacity $C_o$ for IIB	0.705 $\mu$ F				
Max. permissible external capa.IIA	2330 nF				
Max. permissible external inductance $L_o$ for IIC	2.3 mH				
Max. permissible external inductance $L_o$ for IIB	17 mH				
Max. permissible external inductance $L_o$ for IIA	28 mH				
Max. voltage $U_i$	30 V				
Max. voltage $U_o$ isolation amplifier	4.1 V				
Max. current $I_i$ note	Internally limited				
Max. power $P_i$	100 mW				
Internal capacitance	Negligible				
Internal capacitance isolation amplifier	Negligible				
Internal inductance	Negligible				
Internal inductance $L_i$ isolation amplifier	Negligible				
Safety-related max. voltage	253 V AC				
Intrinsically safe limiting values inductance $L_o$ /capacitance $C_o$	Jointly connectable inductance $L_o$ /capacitance $C_o$				
IIC	$L_o$ [mH]	2 mH	1 mH	0.500 mH	0.200 mH
	$C_o$ [ $\mu$ F]	0.042 $\mu$ F	0.056 $\mu$ F	0.072 $\mu$ F	0.090 $\mu$ F
IIB	$L_o$ [mH]	17 mH	2 mH	0.500 mH	0.200 mH
	$C_o$ [ $\mu$ F]	0.290 $\mu$ F			
IIA	$L_o$ [mH]	28.000 mH	2.000 mH	1.000 mH	0.200 mH
	$C_o$ [ $\mu$ F]	0.410 $\mu$ F	0.320 $\mu$ F	0.540 $\mu$ F	0.820 $\mu$ F
IIIC	$L_o$ [mH]	17.000 mH	2.000 mH	0.500 mH	0.200 mH
	$C_o$ [ $\mu$ F]	0.290 $\mu$ F	0.320 $\mu$ F	0.460 $\mu$ F	0.600 $\mu$ F
I	$L_o$ [mH]	40.000 mH	20.000 mH	0.500 mH	0.100 mH
	$C_o$ [ $\mu$ F]	0.480 $\mu$ F	0.660 $\mu$ F	0.810 $\mu$ F	1.200 $\mu$ F

**Auxiliary Power**

Auxiliary power	24 V DC
Auxiliary power nominal voltage	24 V DC
Auxiliary power voltage range	18 to 31.2 V
Voltage range residual ripple	$\leq 3,6 V_{SS}$
Nominal current	100 mA
Auxiliary power max. power dissipation	1.7 W
Power consumption	2.3 W
Polarity reversal protection	Yes
Undervoltage monitoring	Yes
Operation indication	Green "PWR" LED

**Galvanic Isolation**

Test voltage as per standard	IEC EN 60079-11
Ex i input to output	1.5 kV AC
Ex i input to auxiliary power	1.5 kV AC
Ex i input to Ex i input	500 V
Test voltage as per standard	EN 50178
Output to auxiliary power	350 V AC
Output to output	350 V AC

**Input**

Input function	Isolation amplifier Transmitter power unit
Input	0/4 ... 20 mA with HART
Input signal	0/4 to 20 mA with HART
Function range input	0 ... 24 mA
Max. input current, mA sources	50 mA
Input for open-circuit voltage $U_a$	$\leq 26 V$
Short-circuit current	$\leq 35 mA$
Ex i input supply voltage for transmitter	16 V at 20 mA (for 2-wire)
Supply voltage for transmitter	$\geq 16 V$ at 20 mA
Line fault and loss of power signalisation	- Contact (30 V/100 mA), closed against earth in case of error - pac-Bus, potential-free contact (30 V/100 mA)
Input resistance	$\leq 100 \text{ ohm}$

**Output**

Output	Passive with HART
Function range output	0 – 24 mA
Output A	Passive
Output B	Passive
Output voltage	$\leq 30 V$
Max. load resistance $R_L$ HART	See characteristic curve
Max. load resistance $R_L$ note	See characteristic curve
Output residual ripple	$\leq 40 \mu A_{eff}$
Settling time 10-90%	$\leq 100 \mu s$
Temperature influence error limits	$\leq 0.05\% / 10 K$
Deviation	$\leq 0,1 \%$
Behaviour of the output	= input signal
Behaviour of the output note	Accuracy, typical data expressed as % of calibrated span (20 mA) at $U_N$ , 23 °C

**Ambient Conditions**

Ambient temperature	-20 °C ... +70 °C (Single device) -20 °C ... +60 °C (Group assembly)
Ambient temperature	-4 °F ... +158 °F (Single device) -4 °F ... +140 °F (Group assembly)
Storage temperature	-40 °C ... +80 °C
Storage temperature	-40 °F ... +176 °F
Maximum relative humidity	95%
Use at the height of	< 2000 m
Electromagnetic compatibility	Tested to the following standards and regulations: EN 61326-1 For use in industrial areas; NAMUR NE 21

**Mechanical Data**

Degree of protection (IP)	IP30
Degree of protection (IP) terminals	IP20
Fire resistance (UL 94)	V0
Enclosure material	Polyamide
Connection cross-section	0.2 to 2.5 mm <sup>2</sup> flexible 0.25 to 2.5 mm <sup>2</sup> flexible with core end sleeve
Grid dimension	17.6 mm

**Mechanical Data**

Width	17.6 mm
Width, inches	0.69 in
Height	114.5 mm
Height, inches	4.51 in
Length	108 mm
Length, inches	4.25 in
Mounting depth, inches	4.51 in
Weight	195 g
Weight	0.43 lb

**Mounting / Installation**

Mounting type	DIN rail NS35/15, NS35/7.5
Mounting orientation	Vertical Horizontal
Connection type	Screw terminal
Min. rigid conductor cross section	0.2 mm <sup>2</sup>
Max. rigid conductor cross section	2.5 mm <sup>2</sup>
Min. flex conductor cross section	0.2 mm <sup>2</sup>
Max. flex conductor cross section	2.5 mm <sup>2</sup>
Connection cross-section AWG	24 – 14

**Technical Drawings – Subject to Alterations**

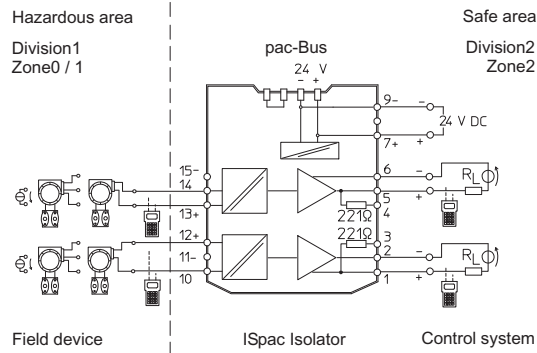

Connection diagram 9160/23-10-10

**Dimensional Drawings (All Dimensions in mm [inches]) – Subject to Alterations**

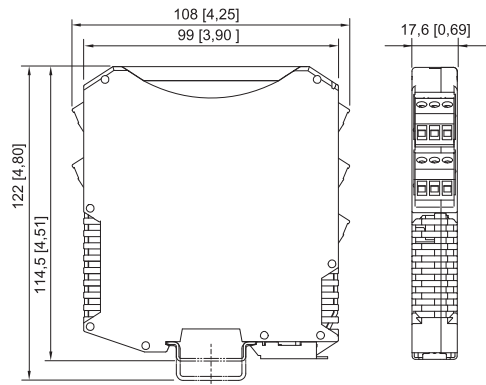

ISpac Series 9143, 9146, 9147, 9160, 9162, 9163, 9165, 9167, 9170, 9172, 9175, 9176, 9180, 9182, 9193, ISbus Series 9412 with screw terminal





## Reference Data Sheet

No : 1404-2



- Compact one- and two-channel Ex i output isolating repeater
- Variants with wire-breakage and short-circuit monitoring system, which can be disconnected and features a signalling contact
- Can be used up to SIL 2 (IEC/EN 61508)

WebCode 9165A



## Technical Data

**Explosion Protection**

Application range (Zones)	2
Ex interface zone	0 1 2 20 21 22
IECEX gas certificate	IECEX BVS 10.0011 X
IECEX gas explosion protection	Ex nA nC [ja Ga] IIC T4 Gc
IECEX dust certificate	IECEX BVS 10.0011 X
IECEX dust explosion protection	[Ex ia Da] IIIC
ATEX gas certificate	DMT 03 ATEX E 012 X
ATEX gas explosion protection	⊕ II 3 (1) G Ex nA nC [ja Ga] IIC T4 Gc
ATEX dust certificate	DMT 03 ATEX E 012 X
ATEX dust explosion protection	⊕ II (1) D [Ex ia Da] IIIC
FMus certificate	FM16US0122X
cFM certificate	FM16CA0067X
Marking cFMus	Class I, Div. 2, Groups A,B,C,D; Class I, Zone 2, AEx/Ex nA nC Group IIC AIS Class I,II,III, Div. 1, Groups A,B,C,D,E,F,G; Class I, Zone 0, [AEx ia]/[Ex ia] IIC T4 at Ta = 70°C See Doc. 91 656 01 31 1
EAC certificate	TS RU S-DE.GB04.B.00353
EAC gas explosion protection	⊕ 2 Ex nA nC [ja Ga] IIC T4 Gc X
EAC dust explosion protection	⊕ [Ex ia Da] IIIC
Certificates	ATEX (BVS), Canada (FM), EAC (ENDCE), IECEx (BVS), India (PESO), Korea (KTL), Russia (Meteorological certificate), SIL (exida), USA (FM)

---

**Explosion Protection**

Ship approval	CCS, EU RO MR (DNV GL)
Notes	CCC, UKCA certificate available from 2022 onward

**Safety Data**

Max. voltage $U_o/V_{oc}$	25.6 V
Max. current $I_o/I_{sc}$	96 mA
Max. power $P_o$	605 mW
Max. permissible external capacitance $C_o/C_a$ for IIC	0.103 $\mu$ F
Max. permissible external capacitance $C_o/C_a$ for IIB	0.8 $\mu$ F
Max. permissible external inductance $L_o/L_a$ for IIC	1.9 mH
Max. permissible external inductance $L_o/L_a$ for IIB	11 mH
Internal capacitance	Negligible
Internal inductance	Negligible
Safety-related max. voltage	253 V

**Functional Safety**

SIL	2
-----	---

**Electrical Data**

Number of channels	1
LFD relay	Yes
Communication signal	HART

**Auxiliary Power**

Auxiliary power	24 V DC
Nominal voltage $V_{nom}$	24 V DC
Auxiliary power voltage range	18 to 31.2 V
Voltage range residual ripple	$\leq 3,6 V_{SS}$
Nominal current	55 mA
Power consumption	1.3 W
Max. power dissipation	1.1 W
Polarity reversal protection	Yes
Operation indication	Green "PWR" LED

**Galvanic Isolation**

Test voltage as per standard	IEC EN 60079-11
Ex i output to fault message contact	1.5 kV AC
Ex i output to auxiliary power	1.5 kV AC
Ex i output to input	1.5 kV AC
Test voltage as per standard	EN 50178
Fault message contact to auxiliary power	350 V AC
Input to auxiliary power	350 V AC
Fault message contact to input	350 V AC

**Input**

Input	0/4 to 20 mA with HART
Input signal	0/4 to 20 mA with HART

---

---

**Input**

Function range input	0 – 24 mA
Maximum input current	50 mA
Input resistance	175/400 $\Omega$
LF response threshold	$I_E > 3.6 \text{ mA}$
Behaviour of the input with LF	$R_E \geq 100 \text{ k}\Omega$

**Output**

Output	0/4 to 20 mA with HART
Output signal	0/4 to 20 mA with HART
Function range output	0 – 24 mA
Max. load resistance $R_L$	800 $\Omega$
Min. $R_L$ for KS detection	150 $\Omega$
Output residual ripple	$\leq 50 \text{ mV}$
Open-circuit voltage $U_a$	22,5 V
Settling time 10-90%	$\leq 100 \mu\text{s}$
Average measurement fault	0,10%
Temperature influence error limits	$\leq 0.05\%/10 \text{ K}$
LF switch user adjustment	Activated/deactivated
Indication of line fault	Red "LF" LED
Wire breakage error detection	$U_A > 16 \text{ V}$
Short circuit error detection	$R_L < 50 \text{ ohm}$
Line fault and loss of power signalization	Contact (30 V / 100 mA) closed to ground in case of fault pac-Bus, floating contact (30 V / 100 mA)

**Ambient Conditions**

Ambient temperature $^{\circ}\text{C}$	-20 $^{\circ}\text{C}$ ... +70 $^{\circ}\text{C}$ (Single device) -20 $^{\circ}\text{C}$ ... +60 $^{\circ}\text{C}$ (Group assembly)
Ambient temperature $^{\circ}\text{F}$	-4 $^{\circ}\text{F}$ ... +158 $^{\circ}\text{F}$ (Single device) -4 $^{\circ}\text{F}$ ... +140 $^{\circ}\text{F}$ (Group assembly)
Storage temperature $^{\circ}\text{C}$	-40 $^{\circ}\text{C}$ ... +80 $^{\circ}\text{C}$
Storage temperature $^{\circ}\text{F}$	-40 $^{\circ}\text{F}$ ... +176 $^{\circ}\text{F}$
Max. relative humidity	95%
Use at the height of	< 2000 m
Electromagnetic compatibility	Tested to the following standards and regulations: EN 61326-1 Use in industrial environment

**Mechanical Data**

Degree of protection (IP)	IP30
Degree of protection (IP) terminals	IP20
Fire resistance (UL 94)	V0
Enclosure material	Polyamide
Grid dimension	17.6 mm
Width	17.6 mm
Width, inches	0.69 in
Height	114.5 mm
Height, inches	4.51 in
Length	108 mm
Length, inches	4.25 in

---

### Mechanical Data

Weight	0.18 kg
Weight	0.4 lb

### Mounting / Installation

Mounting type	DIN rail NS35/15, NS35/7.5
Mounting orientation	Horizontal Vertical
Connection type	Screw terminal
Min. rigid conductor cross section	0.2 mm <sup>2</sup>
Max. rigid conductor cross section	2.5 mm <sup>2</sup>
Min. flex conductor cross section	0.2 mm <sup>2</sup>
Max. flex conductor cross section	2.5 mm <sup>2</sup>
Connection cross-section AWG	24 – 13

### Technical Drawings – Subject to Alterations

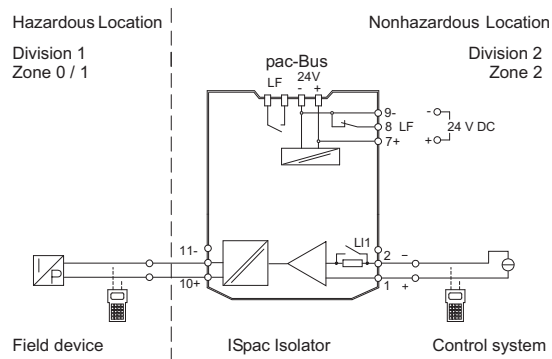

Connection diagram 9165/16-11-11

### Dimensional Drawings (All Dimensions in mm [inches]) – Subject to Alterations

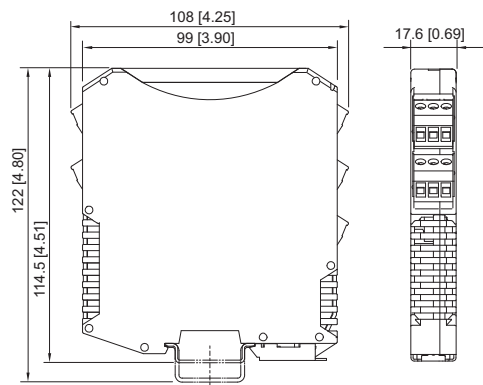



Reference Data Sheet

No : 1404-3



- Can be used up to SIL 2 (IEC/EN 61508)
- Wire-breakage and short-circuit monitoring system, which can be disconnected and issues alerts
- Optional line error transparency: The device notifies the control system directly of any field-side line faults via the signal output.

WebCode 9170A



Technical Data

**Explosion Protection**

Application range (Zones)	2
Ex interface zone	0 1 2 20 21 22
IECEX gas certificate	IECEX BVS 09.0041 X
IECEX gas explosion protection	Ex nA nC [ja Ga] IIC T4 Gc
IECEX dust certificate	IECEX BVS 09.0041 X
IECEX dust explosion protection	[Ex ia Da] IIIC
ATEX gas certificate	DMT 02 ATEX E 195 X
ATEX gas explosion protection	⊕ II 3 (1) G Ex nA nC [ja Ga] IIC T4 Gc
ATEX dust certificate	DMT 02 ATEX E 195 X
ATEX dust explosion protection	⊕ II (1) D [Ex ia Da] IIIC
FMus certificate	FM16US0122X
cFM certificate	FM16CA0067X
Marking cFMus	Class I, Div. 2, Groups A,B,C,D; Class I, Zone 2, Group IIC AIS Class I,II,III, Div. 1, Groups A,B,C,D,E,F,G; Class I, Zone 0, [AEx ia]/[Ex ia] IIC T4 at Ta = 70°C See Doc. 91 706 02 31 1
EAC certificate	EAEU RU S-DE.HA91.B.00100/20
EAC gas explosion protection	⊕ 2 Ex nA nC [ja Ga] IIC T4 Gc X
EAC dust explosion protection	⊕ [Ex ia Da] IIIC X

---

**Explosion Protection**

Certificates	ATEX (BVS), Brazil (ULB), Canada (FM), EAC (ENDCE), IECEx (BVS), India (PESO), Korea (KGS), SIL (exida), USA (FM)
Ship approval	CCS, EU RO MR (DNV GL)
Notes	CCC, UKCA certificate available from 2022 onward
Installation	in Zone 2, Division 2 and in the safe area
Further information	see respective certificate and operating instructions

**Safety Data**

Max. voltage $U_o/V_{oc}$	9.6 V
Max. current $I_o/I_{sc}$	10 mA
Max. power $P_o$	24 mW
Max. permissible external capacitance $C_o/C_a$ for IIC	3.6 $\mu$ F
Max. permissible external capacitance $C_o/C_a$ for IIB	26 $\mu$ F
Max. permissible external inductance $L_o/L_a$ for IIC	350 mH
Max. permissible external inductance $L_o/L_a$ for IIB	1000 mH
Internal capacitance	2.42 nF
Internal inductance	Negligible
Safety-related max. voltage	253 V

**Functional Safety**

SIL	2
-----	---

**Electrical Data**

Number of channels	2
LFD relay	Yes

**Auxiliary Power**

Auxiliary power	24 V DC
Auxiliary power voltage range	18 to 31.2 V
Voltage range residual ripple	$\leq 3,6 V_{ss}$
Nominal current	55 mA
Power consumption	1.3 W
Max. power dissipation	1.3 W
Polarity reversal protection	Yes
Undervoltage monitoring	Yes
Operation indication	Green "PWR" LED

**Galvanic Isolation**

Test voltage as per standard	IEC EN 60079-11
Ex i input to output	1.5 kV AC
Ex i input to auxiliary power	1.5 kV AC
Galv.sep. Ex i input to FMC	1.5 kV AC
Ex i input to Ex i input	500 V AC
Test voltage as per standard	EN 50178
Output to auxiliary power	1,1 kV AC
Output to output	1,1 kV AC
Fault message contact to auxiliary power	350 V AC

---

---

**Galvanic Isolation**

Galv. separation FMC to output	1,1 kV AC
--------------------------------	-----------

**Input**

Input signal	As per EN 60947-5-6 (NAMUR)
Input current for ON	$\geq 2.1$ mA
Input current for OFF	$\leq 1.2$ mA
Hysteresis	Approx. 0.2 mA
Input internal resistance $R_i$	1000 $\Omega$
Input for open-circuit voltage $U_a$	8,2 V
Short-circuit current	$\leq 8.2$ mA

**Output**

Output per channel	2 NO – signal relay
Output	2 NO – signal relay
Min. output load condition	1 V / 0.1 mA
Max. output DC load condition	125 V / 1 A
Max. output AC load condition	125 V / 1 A
Output switching capacity	25 W / 50 VA
Output electrical service life	$5 \times 10^5$ at 24 V/1 A
Output mechanical service life	$1 \times 10^8$ operating cycles
Recommended back-up fuse	$\leq F$ 1 A AC/DC
Output switching frequency	15 Hz
Switching delay ON/OFF	5 ms
Switching delay OFF/ON	5 ms
INV switch user adjustment	Activated/deactivated
Switching state indication	Yellow "OUT" LED per channel
Fault message contact switching capacity	30 V / 100 mA
LF switch user adjustment	Activated/deactivated
Indication of line fault	Red "LF" LED for each channel
Wire breakage error detection	$I_E < 0.05$ to 0.35 mA
Short circuit error detection	$R_E < 100$ to 360 ohm
Line fault and loss of power signalization	Contact (30 V / 100 mA) closed to ground in case of fault pac-Bus, floating contact (30 V / 100 mA)

**Ambient Conditions**

Ambient temperature °C	-20 °C ... +70 °C (Single device) -20 °C ... +60 °C (Group assembly)
Ambient temperature °F	-4 °F ... +158 °F (Single device) -4 °F ... +140 °F (Group assembly)
Storage temperature °C	-40 °C ... +80 °C
Storage temperature °F	-40 °F ... +176 °F
Max. relative humidity	95%
Use at the height of	< 2000 m
Electromagnetic compatibility	Tested to the following standards and regulations: EN 61326-1 Use in industrial environment; NAMUR NE 21

**Mechanical Data**

Degree of protection (IP)	IP30
Degree of protection (IP) terminals	IP20

---

## Mechanical Data

Fire resistance (UL 94)	V0
Enclosure material	Polyamide
Grid dimension	17.6 mm
Width	17.6 mm
Width, inches	0.69 in
Height	114.5 mm
Height, inches	4.51 in
Length	128 mm
Length, inches	5.04 in
Weight	0.225 kg
Weight	0.5 lb

## Mounting / Installation

Mounting type	DIN rail NS35/15, NS35/7.5
Mounting orientation	Vertical Horizontal
Connection type	Spring clamp terminal
Min. rigid conductor cross section	0.2 mm <sup>2</sup>
Max. rigid conductor cross section	2.5 mm <sup>2</sup>
Min. flex conductor cross section	0.2 mm <sup>2</sup>
Max. flex conductor cross section	2.5 mm <sup>2</sup>
Connection cross-section AWG	24 – 13

## Technical Drawings – Subject to Alterations

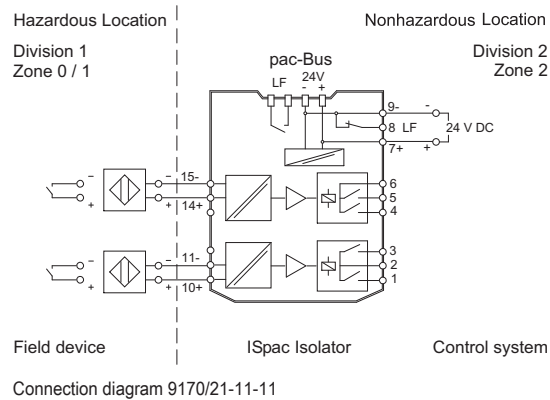

## Dimensional Drawings (All Dimensions in mm [inches]) – Subject to Alterations

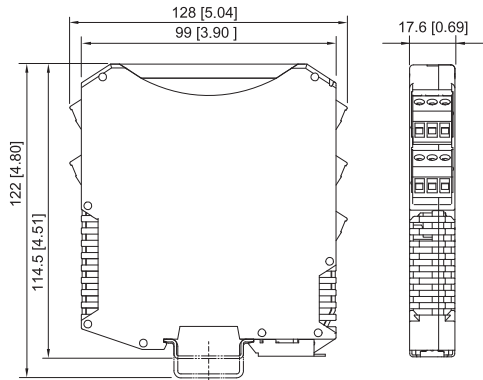

ISpac Series 9146, 9147, 9160, 9162, 9163, 9165,  
9167, 9170, 9172, 9175, 9176, 9180, 9182, 9193,  
Fieldbus Power Supply Series 9412 with spring clamp  
terminal





## Reference Data Sheet

No : 1404-4



- Two-channel variants reduce the amount of space required
- For use up to SIL 3 (IEC/EN 61508)
- A wire breakage and short-circuit monitoring system, which can be disconnected and includes messages

MY R. STAHL 9175A



## Technical Data

### Explosion Protection

Application range (zones)	2
Ex interface zone	0 1 2 20 21 22
IECEX gas certificate	IECEX BVS 10.0050 X
IECEX gas explosion protection	Ex nA nC [ja Ga] IIC T4 Gc
IECEX dust certificate	IECEX BVS 10.0050 X
IECEX dust explosion protection	[Ex ia Da] IIIC
ATEX gas certificate	DMT 03 ATEX E 043 X
ATEX gas explosion protection	⊕ II 3 (1) G Ex nA nC [ja Ga] IIC T4 Gc
ATEX dust certificate	DMT 03 ATEX E 043 X
ATEX dust explosion protection	⊕ II (1) D [Ex ia Da] IIIC
FMus certificate	FM16US0122X
cFM certificate	FM16CA0067X
Marking cFMus	Class I, Div. 2, Groups A,B,C,D; Class I, Zone 2, Group IIC AIS Class I,II,III, Div. 1, Groups A,B,C,D,E,F,G; Class I, Zone 0, [AEx ia]/[Ex ia] IIC T4 Mounting vert. at Ta = 70°C , or horizontal Ta = 60°C See Doc. 91 756 01 31 1
cULus certificate	E81680V1S7
Marking cULus	prov. intr. safe circ. f.u.in Class I,II,III, Groups A,B,C,D,E,F,G; See Doc. 91 756 01 31 3
Certificates	ATEX (BVS), Brazil (ULB), Canada (FM), China (NEPSI), IECEX (BVS), Korea (KTL), SIL (exida), USA (FM), USA (UL)
Ship approval	CCS, EU RO MR (DNV)

## Explosion Protection

Declaration of Conformity ATEX (EUK), China (CCC)

## Safety Data

Max. voltage $U_o$	27.6 V	
Max. current $I_o$ (Ex ia)	110 mA	
Max. current $I_o$ (Ex ib)	50 mA	
Max. power $P_o$	760 mW	
Max. permissible external capacity $C_o$ for IIC	0.085 $\mu$ F	
Max. permissible external capacity $C_o$ for IIB	0.667 $\mu$ F	
Max. permissible external inductance $L_o$ for IIC	1.2 mH	
Max. permissible external inductance $L_o$ for IIB	9 mH	
Internal capacitance	1.1 nF	
Internal inductance	Negligible	
Safety-related max. voltage	253 V	
Intrinsically safe limiting values inductance $L_o$ /capacitance $C_o$	Max. connectable inductance $L_o$ /capacitance $C_o$ , 2 parallel channels	
IIC	$L_o$ [mH] $C_o$ [ $\mu$ F]	
IIB	$L_o$ [mH] $C_o$ [ $\mu$ F]	1,8 mH 0.665 $\mu$ F
IIIC	$L_o$ [mH] $C_o$ [ $\mu$ F]	1.800 mH 0.665 $\mu$ F

## Functional Safety

SIL	3
HFT	0
SFF	94%
Lambda SU	166 FIT
Lambda DD	0 FIT
Lambda DU	9 FIT
PFD <sub>avg</sub> at T <sub>proof</sub> 1 year	4,25E-05
PFD <sub>avg</sub> at T <sub>proof</sub> 2 years	8,12E-05
PFD <sub>avg</sub> at T <sub>proof</sub> 5 years	1,97E-04

## Electrical Data

Number of channels	2
LFD relay	Yes
Short circuit error detec. OFF	50 ... 90 $\Omega \pm 8 \Omega$ /10 K

## Auxiliary Power

Auxiliary power	24 V DC
Auxiliary power voltage range	18 to 31.2 V
Voltage range residual ripple	$\leq 3,6 V_{SS}$
Nominal current	140 mA
Power consumption	3.4 W
Max. power dissipation	2.4 W

---

### Auxiliary Power

Polarity reversal protection	Yes
Undervoltage monitoring	Yes
Operation indication	Green "PWR" LED

### Galvanic Isolation

Test voltage as per standard	IEC EN 60079-11
Galvanic separation Ex i output to input	1,5 kV AC
Galvanic separation Ex i output to HE	1,5 kV AC
Galvanic separation Ex i output to FMC	1,5 kV AC
Ex i input to Ex i input	N/A
Test voltage as per standard	EN 50178
Fault message contact to auxiliary power	350 V AC
Input to auxiliary power	350 V AC
Input to input	350 V AC
Fault message contact to input	350 V AC

### Input

Input	In accordance with EN 61131-2
Input voltage for ON	15 – 31.2 V
Input voltage for OFF	0 – 5 V
Control current	< 5 mA

### Output

Output open-circuit voltage $U_a$	25 V
Max. output current $I_{a\max}$	35 mA
Max. output current $I_a$ note	Parallel channels: 70 mA
Internal resistance $R_i$ note	250 $\Omega$ /parallel: 125 $\Omega$
Output residual ripple	< 50 mV
Output switching frequency	$\leq$ 200 Hz
Switching delay ON/OFF	$\leq$ 1 ms
Switching delay OFF/ON	$\leq$ 1 ms
Switching state indication	Yellow "OUT" LED
Fault message contact switching capacity	30 V / 100 mA
LF switch user adjustment	Activated/deactivated
Indication of line fault	Red "LF" LED
Wire breakage error detection	> 15 k $\Omega$ /> 7.5 k $\Omega$
Short circuit error detection	50 to 90 ohm $\pm$ 8 ohm/10 K
Wire breakage error detection OFF	> 15 k $\Omega$ / > 7,5 k $\Omega$
KS parallel error detection	25 to 45 ohm $\pm$ 8 ohm/10 K
Line fault and loss of power signalisation	- Contact (30 V/100 mA), closed against earth in case of error - pac-Bus, potential-free contact (30 V/100 mA)
Test current	2.3 mA (at 100-ohm load)
Parallel channels test current	0.72 mA (at 15-k $\Omega$ load)
Note	You can find a list of connectible Ex i solenoid valves on our homepage at <a href="http://www.r-stahl.com">www.r-stahl.com</a> (WebCode 9175A)

---

### Ambient Conditions

Ambient temperature	-20 °C ... +70 °C (Single device) -20 °C ... +60 °C (Group assembly)
Ambient temperature	-4 °F ... +158 °F (Single device) -4 °F ... +140 °F (Group assembly)
Storage temperature	-40 °C ... +80 °C
Storage temperature	-40 °F ... +176 °F
Maximum relative humidity	95%
Use at the height of	< 2000 m
Electromagnetic compatibility	Tested to the following standards and regulations: EN 61326-1 For use in industrial areas; NAMUR NE 21

### Mechanical Data

Degree of protection (IP)	IP30
Degree of protection (IP) terminals	IP20
Fire resistance (UL 94)	V0
Enclosure material	Polyamide
Grid dimension	17.6 mm
Width	17.6 mm
Width, inches	0.69 in
Height	114.5 mm
Height, inches	4.51 in
Length	128 mm
Length, inches	5.04 in
Weight	111 g
Weight	0.24 lb

### Technical Drawings – Subject to Alterations

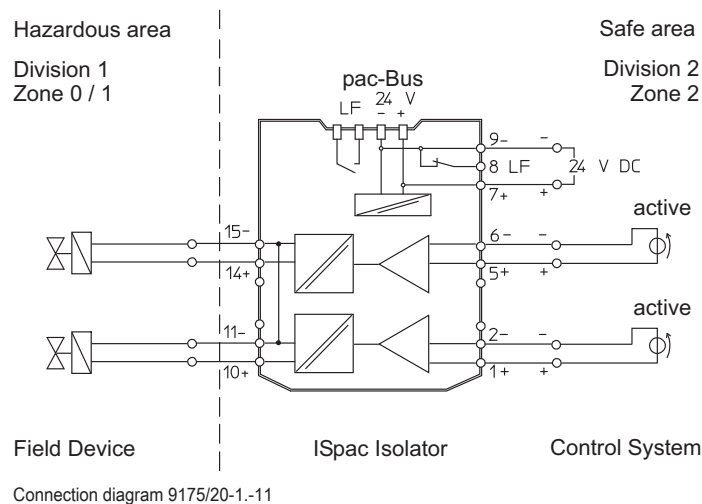

### Dimensional Drawings (All Dimensions in mm [inches]) – Subject to Alterations

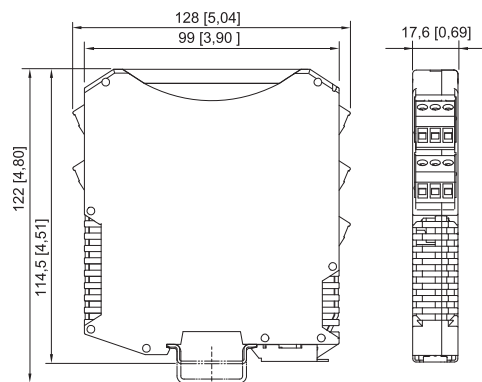

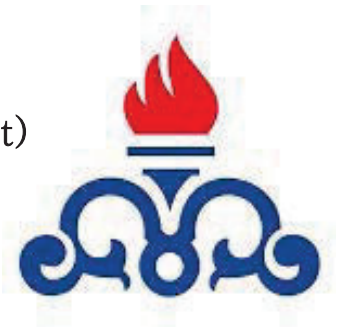

Reference Data Sheet

No : 1404-5

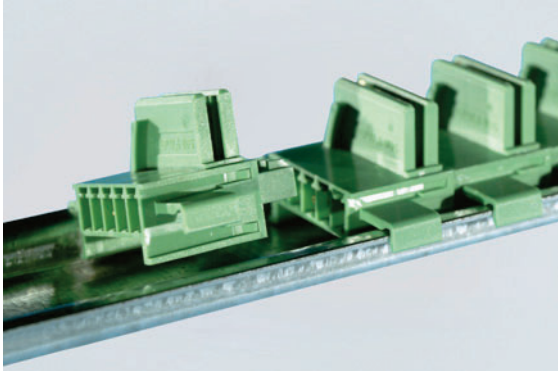

- ISpac devices are quick to wire, reducing costs
- Can be installed on standard DIN rails without tools by simply snapping into place – can be expanded at any time
- Suitable for industrial environments subject to vibration

MY R. STAHL 9194A



Technical Data

Explosion Protection

Application range (Zones)	2
IECEX gas certificate	IECEX BVS 10.0042 X
IECEX gas explosion protection	Ex ec IIC T4 Gc
ATEX gas certificate	BVS 03 ATEX E 213 X
ATEX gas explosion protection	Ex II 3 G Ex ec IIC T4 Gc
FMus certificate	FM16US0122X
cFM certificate	FM16CA0067X
Marking cFMus	Class I, Div. 2, Groups A,B,C,D; Class I, Zone 2, Group IIC T4 at Ta = 70°C See Doc. 91 956 01 31 1
Certificates	ATEX (BVS), Brazil (ULB), Canada (FM), China (NEPSI), IECEX (BVS), India (PESO), USA (FM)
Ship approval	CCS, EU RO MR (DNV)
Declaration of Conformity	ATEX (EUK), China (CCC)

Electrical Data

Connections using pac-Bus terminal set 9194/50-01 or supply module 9193/21-11-11.

Connection diagram

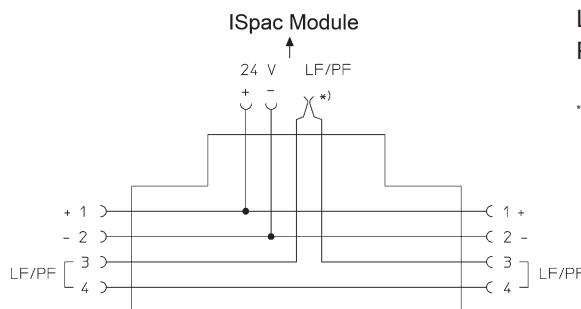

LF = Line fault  
PF = Auxiliary power failure

<sup>\*)</sup> Self-closing contact

### Auxiliary Power

Nominal voltage $V_{nom}$	24 V DC
Nominal current	4 A

### Ambient Conditions

Ambient temperature °C	-20 °C ... +70 °C
Ambient temperature °F	-4 °F ... +158 °F -4 °F ... +158 °F
Storage temperature °C	-40 °C ... +80 °C
Storage temperature °F	-40 °F ... +176 °F
Max. relative humidity	95%
Use at the height of	< 2000 m

### Mechanical Data

Degree of protection (IP) terminals	IP20
Fire resistance (UL 94)	V0
Enclosure material	PA 6.6
Grid dimension	17.6 mm
Width	17.6 mm
Width, inches	0.69 in
Height	20.3 mm
Height, inches	0.82 in
Length	36.3 mm
Length, inches	1.45 in
Mounting depth, inches	0.82 in
Weight	4 g
Weight	0.01 lb

### Mounting / Installation

Mounting type	DIN rail NS35/15, NS35/7.5
Mounting orientation	Horizontal Vertical

### Dimensional Drawings (All Dimensions in mm [inches]) – Subject to Alterations

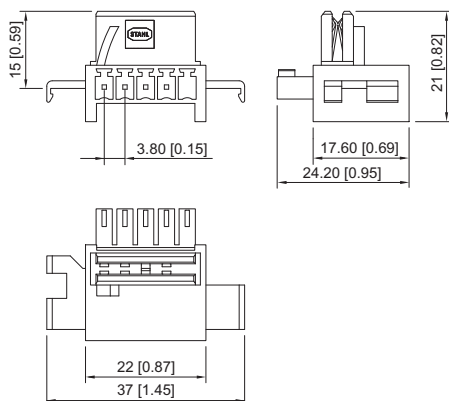

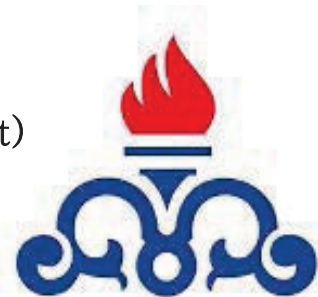

## Reference Data Sheet

No : 1404-6

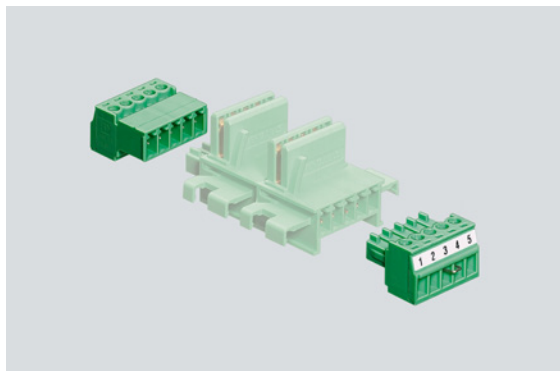

- Reduced costs thanks to faster wiring of ISpac devices
- Mounted and snapped onto standard DIN rails – can be extended at any time
- Suitable for industrial environments subject to vibration

MY R. STAHL 9194A



## Technical Data

## Explosion Protection

Application range (zones)	2
IECEX gas certificate	IECEX BVS 10.0042 X
IECEX gas explosion protection	Ex ec IIC T4 Gc
ATEX gas certificate	BVS 03 ATEX E 213 X
ATEX gas explosion protection	Ex II 3 G Ex ec IIC T4 Gc
FMus certificate	FM16US0122X
cFM certificate	FM16CA0067X
Marking cFMus	Class I, Div. 2, Groups A,B,C,D; Class I, Zone 2, IIC T4 at Ta = 70°C
Certificates	ATEX (BVS), Canada (FM), IECEX (BVS), India (PESO), USA (FM)
Declaration of Conformity	ATEX (EUK)

## Electrical Data

Connections	5-pole screw terminals, max. 1.5 mm <sup>2</sup>
-------------	--

## Auxiliary Power

Nominal voltage	24 V DC
Nominal current	4 A

## Ambient Conditions

Ambient temperature	-20 °C ... +70 °C
Ambient temperature	-4°F ... +158°F
Storage temperature	-40 °C ... +80 °C
Storage temperature	-40°F ... +176°F
Maximum relative humidity	95%
Use at the height of	< 2000 m

## Mechanical Data

Degree of protection (IP) terminals	IP20
Fire resistance (UL 94)	V0
Enclosure material	PA 6.6

## Mechanical Data

AWG clamping range	28 – 16
Connection cross-section AWG	28 ... 16
Weight	8 g
Weight	0.02 lb

## Mounting / Installation

Mounting type	DIN rail NS35/15, NS35/7.5
Mounting orientation	Horizontal Vertical
Connection type	Screw terminal
Min. rigid conductor cross section	0.2 mm <sup>2</sup>
Max. rigid conductor cross section	1.5 mm <sup>2</sup>
Min. flex conductor cross section	0.2 mm <sup>2</sup>
Max. flex conductor cross section	1.5 mm <sup>2</sup>
Connection cross-section AWG	24 – 16

## Technical Drawings – Subject to Alterations

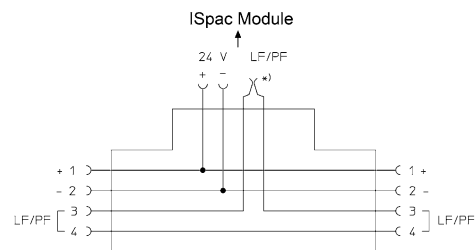

9194 connection diagram

We reserve the right to make alterations to the technical data, dimensions, weights, designs and products available without notice. The illustrations cannot be considered binding.