



Document No. : ۹۰۰-SPC-A۴-IN-۰۰۰۹

Rev.: ۰

Title: INSTRUMENTATION GENERAL SPECIFICATION

Page: A

REV. PAGE	۰	۱	۲	۳	۴	۵	REV. PAGE	۰	۱	۲	۳	۴	۵	REV. PAGE	۰	۱	۲	۳	۴	۵
A	X																			
۱	X																			
۲	X																			
۳	X																			
۴	X																			
۵	X																			
۶	X																			
۷	X																			
۸	X																			
۹	X																			
۱۰	X																			
۱۱	X																			
۱۲	X																			
۱۳	X																			
۱۴	X																			
۱۵	X																			
۱۶	X																			
۱۷	X																			
۱۸	X																			
۱۹	X																			
۲۰	X																			

۵					
۴					
۳					
۲					
۱					
۰	Sep. ۱۳, ۲۰۲۱	M.Asgari	M.Nazeri Nasab	M.Asadi	IFA
Rev	Date	Prepared By	Checked By	Approved By	Status
Discipline					

Document Revisions



National Petroleum Company Co.
Research and Technology

PP-PE Pilot Plant

Document No. : 900-SPC-A4-IN-0009

Rev.: 0

Title: INSTRUMENTATION GENERAL SPECIFICATION

Page: 1

TABLE OF CONTENTS

1. SCOPE
2. TECHNICAL REQUIREMENTS
3. BASIC DESIGN VALUES
4. MEASUREMENT UNITS
5. INSTRUMENT GENERAL REQUIREMENTS
6. CONTROL ROOM
7. LOCAL PANELS
8. ALARMS AND SHUTDOWNS
9. CONNECTIONS
10. FLOW INSTRUMENTS
11. LEVEL INSTRUMENTS
12. PRESSURE INSTRUMENTS
13. TEMPERATURE INSTRUMENTS
14. CONTROL VALVES
15. PRESSURE RELIEF VALVES
16. ANALYZERS



۱. SCOPE

This specification covers the minimum general requirements for the instrumentation and control system design for PP-PE Pilot Plant in NPC-RT plant, Arak, Iran.

For instrumentation systems and components, as far as mechanical and electrical characteristics and performances are concerned, the present general specification will be used, and specific detailed specifications will be issued for each system and/or component. In case of discrepancy, information contained in the particular instrument specification and data sheet will take precedence over the general specification. The instrument design specification will be updated to include all the requirements of the project during detail engineering and is subject to the client's approval.

Any deviation from the present specification at any stage of the project will be clearly stated to the Contractor/Client by the Vendor or the Bidder. If any variation or addition is required in individual cases, they will be shown on material data-sheets. Any deviation from data-sheets or specifications, must be approved in writing by Contractor/Client, otherwise the equipment will be rejected at factory inspection.

۲. TECHNICAL REQUIREMENTS

- ۲.۱. Instruments and control equipment will be specified on standard data sheet formats and by written detailed specification and description.
- ۲.۲. Design methods and materials will be mainly in accordance with NPCS standards while the latest editions of the following standards as well as contractual codes and requirements are applicable:

- ISA Instrumentation Standards:

- ISA S ۰-۱ : Identification and Symbolization ۱۹۹۲
- ISA S ۰-۲ : Graphic symbols for logic diagrams ۱۹۹۲
- ISA S ۰-۳ : Graphic symbols for distributed control/shared display instrumentation, logic and computer systems
- ISA S ۱۸-۱ : Alarm and sequences
- ISA S ۷۰-۱ : Control valve sizing, equations
- ISA S ۷۰-۳ : Face to Face dimensions of globe type control valves
- ISA S ۷۰-۱۹ : Hydraulic testing of control valves ۱۹۹۱
- ISA S ۶۱,۱ : Procedures for executive function for process input output and bit manipulation
- ISA S ۶۱,۲ : Procedure for file access and the control of file contention.
- ISA RP ۶۰,۸ : Electrical guide for control centers

- ANSI Standards:

- ANSI-B ۱۶-۰ : Steel pipe flanges, flanged valve fitting edition + B۱۶-۰ a (۱۹۹۲)
- ANSI-B ۱۶-۱۰ : Face to face and end to end dimensions of valves
- ANSI-B ۳۱,۳ : Process Piping
- ANSI-B ۱-۲۰,۱ : Pipe threads
- ANSI/FC ۷۰,۲ : Control valve seat leakage
- ANSI/MC ۹۶-۱ : Temperature measurement thermocouples
- ANSI-B ۱۶,۳۷ : Hydro static Testing



• ASME & ASTM Standards:

- ASME, Div 1, : Hydraulic test for safety relief valve, Sect. VIII
- ASTM : Material specifications

• ISO Standards:

- ISO 5167 : Flow measurement with orifices, nozzles and venturi tubes

• BS Standards

- BS 1042 : Methods for measurement of fluid flow in pipes (where not covered by ISO 5167)
- BS 6739 : Instrumentation in process control systems installation design and practice (1986)
- BS 5308 : Instrumentation cables

• IEC Standards:

- IEC 701 : Industrial platinum resistance - thermometer sensors (1983 + AMD 1 1986)
- IEC 947 : Low voltage switchgear and control gear (1990)
- IEC 61131 : Programmable controllers Programming languages.(for DCS/PLC)
- IEC 61108 : DCS/PLC
- IEC 529 : Mechanical Protection degree for enclosures
- IEC 60548 : Industrial Thermocouples- thermometer sensors (for T/C)
- IEC 60751 : Industrial Thermocouples- thermometer sensors (for RTD)
- IEC 337-1 : Switches Contact Rating

• API Standards

- API-RP 501 : Process measurement Instrumentation
- API-RP 504 : Process Instrumentation and control
- API-RP 500 : Process Analyzers
- API-RP 526 : Dimensions of Flanged type Pressure Safety valves
- API-RP 526 : Valves Leakage Limits
- API-RP 500 : Hazardous Area classification

• Other Standards

- NACE- MR-0102 : In Sour Corrosive Services
- AWS D1.1 : American Welding Society for steel structures and Instrument welding.
- CENELEC-50014 to 50020 : Protection of Electrical apparatus in explosive area
- NAMUR : Proximity switch mounting and solenoid valve connection.
- IPS -G-IN-16 : Engineering & material standard for control valves
- IPS-C-IN-16 : Construction & installation standard for control valves

Plant control and process monitoring as well as all operational interlocks and sequences shall be performed by DCS.



Document No. : 900-SPC-A4-IN-0009	Rev.: 0
Title: INSTRUMENTATION GENERAL SPECIFICATION	Page: 4

- 2.3. When it is commercially available all field instruments shall have a protection of at least IP-65 or better according to IEC 60529. In case of non-availability of IP-65 or better, other commercially available IP ratings will be reviewed and approved case by case by the client. Transmitter enclosures shall be rated IP-65 as minimum.
- 2.4. All instruments will be tested and calibrated by the Manufacturer before delivery and a calibration sheet will be supplied with each instrument.
- 2.5. In order to achieve a fail safe design all Alarm, safety and interlock contacts will be closed and solenoid valves and relays shall be energized during normal plant operation.
- 2.6. The actions of valves will be designed in such a way as to keep the plant under safe conditions in case of main electric power or instrument air failure.
- 2.7. Instrumentation system shall be basically electronic type. Final control elements and local loops will be pneumatic. Minimization of pneumatic instruments to be considered. Control valves shall have electro-pneumatic positioner. Electronic transmitters shall be Smart type.
- 2.8. Electronic signals shall be 4-20 mA as standard. Isolated outputs to be considered where required. All transmitters shall be Smart type with HART protocol. Communicator shall be supplied by manufacturer.

Pneumatic signals shall be 0.2-1 Bar.
Solenoid valves will be 24 VDC powered.
Cable Entry size shall be generally M^xX¹,0 mm ISO.
- 2.9. Electronic instruments and circuit boards will be tropicalized against moisture, fungus growth and insect attack and will have a high degree of environmental protection for such a duty as well as protection against corrosive, saline etc. atmospheres.
- 2.10. Electronic instruments construction material of wetted parts shall be in accordance with piping class requirements. Wetted parts shall be, as minimum, AISI 316. Where AISI 316 is not suitable for the application other compatible materials with process fluid at service conditions of pressure and temperature shall be selected as Hastelloy C, Titanium, Monel, etc.
- 2.11. Electronic instruments installed in classified area shall be selected in accordance with CENELEC or IEC code requirements. Electronic instruments in hazardous area shall be basically Intrinsically safe. Where Intrinsic safe instruments are not available Explosion proof or purged instruments shall be selected. Certification shall be provided by a recognized laboratory.

3. BASIC DESIGN VALUES

3.1. All field equipment will be suitable for operation in a corrosive, dusty, saline etc. Atmosphere.

3.2. SITE CONDITION:

- Minimum temp. : - °C
- Maximum temp. : +44°C
- Maximum humidity : 86% in January



3.3. Critical instruments systems and control systems will be supplied by 110V 50 Hz single phase from UPS and 24 VDC.



The UPS (un-interruptible power supply) located in the control building, or in the electrical substation (UPS room) will deliver:

- Frequency : 50 Hz \pm 0.5 Hz
- Voltage : 110 VAC \pm 1.0%

The UPS is limited to feeding the DCS, analyzers and other specific instruments when required. Instruments such as transmitters, transducers, converters, switches... will be powered by 24 VDC. Power supply will normally be supplied from the DCS or other systems otherwise 24 VDC power supply will be used for solenoid valves.

No voltages other than 24 VDC, and 110 VAC will be used for systems supply except if clearly specified by the Contractor.

3.4. Instrument air supply shall have the following characteristics as minimum:

- Normal Pressure : 1 Barg
- Minimum Pressure : 0.5 Barg
- Design Pressure : 1.5 Barg
- Temperature : Ambient
- Dew Point : -10 °C
- Dust,Oil,Water free

4. MEASUREMENT UNITS

- Density : kg/m³ (kilograms per cubic meter)
- Level : m,cm,mm
- Viscosity : % of range (for indication)
- Viscosity :
 - Liquid : cSt
 - Gas : cp
- Other units:
 - Rotation : rpm (revolutions per minute)
 - Power : kW or kVA
 - Voltage : V (volt)
 - Electrical current : A (ampere)
 - Pressure : barg
 - Flow : m³/hr
 - Mass flow : kg/s , kg/hr
 - Temperature : °C
 - Time : Sec,Minute
 - Distance : Meter



Document No. : 900-SPC-A4-IN-0009	Rev.: 0
Title: INSTRUMENTATION GENERAL SPECIFICATION	Page: 6

0. INSTRUMENT GENERAL REQUIREMENTS

- 0.1. For transmission and control, electronic loops will use a standard 4-20 mA signal. This is based on smart transmission of signal with HART protocol. The electrical instrument signal will increase in level in increase of the process variable.
For temperature instruments, refer to chapter 12 (TEMPERATURE INSTRUMENTS).
- 0.2. Instrument will in general be of the electronic type.
- 0.3. Transmitters may be provided with integral or separate local digital indicator per process requirements.
- 0.4. Millimeters and receiver gauges will be visible and readable at the associated control valve assembly or at the location indicated on the detailed engineering P&ID.
- 0.5. Process control valves with pneumatic actuators will be actuated via I/P positioners (integral with the control valve).
- 0.6. Limit switches shall be proximity type (NAMUR type) 
- 0.7. The component parts of instruments will be of material suitable for the process. Movements or wetted parts for instruments will be stainless steel or better when specified. Materials exposed to the process fluid will be in accordance with the fluid conditions (pressure, temperature, and corrosion). This will be reviewed case by case during detail engineering and is subject to the Client's approval.
- 0.8. All components, particularly if containing electric contacts, will be vibration resistant. All components will be constructed of material which is resistant to corrosion by the process fluid with which they are in contact internally and to the ambient air environment to which they are externally exposed (corrosive, dusty, saline etc. atmospheres).
- 0.9. Instrument cables (analog (4-20 mA), digital signal, RTD and thermocouple cables) will be run separate from power supply cables from the field junction boxes to the control room.
- 0.10. Cables carrying intrinsically safe shall be routed separately with non-IS signal carrying cables.
- 0.11. Instrument air manifolds shall be used for distributing the instrument air to the consumer. Min 20% spare tapping shall be considered in each manifold.
- 0.12. Control actions shall be done as much as possible in the DCS system but Local controllers if any will be specified with one or more of the following actions; the control action will be easily reversible.
 - a. Proportional
 - b. Integral or reset
 - c. Derivative or rate.Generally, temperature controllers will be three term controllers; flow pressure and level will be two term controllers. Integral and derivative actions will have an off position where possible.
- 0.13. Each pneumatic user shall be provided with a 1/2" block valve. the material of block valve shall be 316 SS. An air filter regulator with pressure gauge shall be considered for each user. For control valves the pressure gauge will be installed on the positioner.



Document No. : 900-SPC-A4-IN-0009	Rev.: 1
Title: INSTRUMENTATION GENERAL SPECIFICATION	Page: 4

- , 14. All indicator dials will be white with black graduations. Electronic indicators will be as per supplier standard.
- , 15. All field instruments will be provided with a suitable stainless-steel nameplate bearing whenever applicable, the following information:
 - tag number
 - Manufacturer's name, model and serial number
 - Maximum allowable pressure / temperature for the parts concerned
 - Scale factors
 - Materials of the fluid wetted parts
 - Power voltage and frequency or instrument air pressure
 - Calibrated rangeAll indoor instruments will be provided with at least one nameplate for operating and maintenance purposes.
- , 16. Final drawing and certificates will be issued in the English language.

6. CONTROL ROOM

- 6.1. The main apparatus installed in control room is the cabinets of Distributed Control System (DCS) package PLCs and operator stations.
- 6.2. Cable cross wiring marshalling cabinets, DCS process interface and controller cabinets, DCS historical modules and network modules, marshalling cabinets, electrical distribution panel will be installed in an auxiliary room adjacent to the PCR (process control room).
The DCS operator stations / engineering stations and associated printers will be located in the PCR (process control room).
The UPS cabinets and the UPS batteries will be located in the UPS room and battery room respectively which is in the scope of Electrical.
- 6.3. All instrument cable entries into the control room and auxiliary room from the outside will be via PVC conduit, which will be sealed in order to prevent the ingress of gas or vapors.
- 6.4. No process fluids will be piped into the control room or the auxiliary room.
- 6.5. The process control room and the auxiliary room will be air conditioned, and classified as a general-purpose (unclassified) electrical area. They will also have a false floor for routing of cables and a false ceiling for proper lighting and air conditioning ducting.

7. LOCAL PANELS

All functions for process control of the plant will be done through the Distributed Control System. However, local panels may be provided for main EQUIPMENT, which will be normally controlled by programmable logic controllers (PLC) located in the auxiliary room. The local panels (installed near the EQUIPMENT) will include push buttons, lamps and indicators necessary for local operations, start-up and maintenance (e.g. heater...) and will be the Vendor's standard design.



Document No. : 900-SPC-A4-IN-0009	Rev.: 1
Title: INSTRUMENTATION GENERAL SPECIFICATION	Page: 1

1. ALARMS AND SHUTDOWNS

- 1.1. Alarms and shutdown systems will be generally designed to be fail-safe.
- 1.2. The control systems will be designed in order to protect against tripping from random or spurious signals on deviation from normal operating conditions i.e. to prevent noisy shutdown.

2. CONNECTIONS

- 2.1. Instrument connections and tapping points on vessels or pipes are defined on table #1.
- 2.2. Plant pneumatic signal lines will be 1/2" OD stainless steel tubing and fittings.
- 2.3. All cable runs between the control room and the plant will be made with multi core/pair cables and connected to the field junction boxes.
Cable specifications from the auxiliary room to the field are:
Electronic signals: multi-pair, each pair twisted and screened, overall screened, armored PVC insulated.
On-off signals : multi core, overall screened, armored PVC insulated
- 2.4. The single pair cable specifications are the following:
Electronic signals single pair, twisted, screened, armored, PVC insulated
On-off signals Two Core, armored, PVC insulated, overall sheath
Cable runs in the main control room as well as in the auxiliary room and the plant, will be tagged at each end for identification purposes. For the cable runs in the plant, cable markers will be provided at specific distances to indicate the route of the cable.
- 2.5. Multi-strand copper wires for single pair or triple conductor cables will be used in the auxiliary room, and for cables between field junction boxes and instruments. For other connections, solid copper conductors are preferred.
- 2.6. A maximum voltage drops of 1% at normal loading conditions will be taken into account in the sizing of cables.
- 2.7. 2% spare cores are required in multi core cables and for spare cable inlets to the junction boxes. All spare conductors will be connected to terminals.
- 2.8. Minimum 2% spare space is required in junction boxes.
- 2.9. Screwed terminals will normally be used. Test/disconnect terminals will be used for the connection of field cables in the marshalling cabinets.
- 2.10. Accuracy rating for instruments.

The rated accuracy of individual instruments will be as listed below.

These tolerances will apply to the full-scale reading of the particular instrument, referring to repeatability a deviation of characteristic curve, at constant ambient temperature and a steady power supply (for instruments accuracy values marked with (*) referred to the measured value).



Primary devices:

Standard orifice plates and Venturi tubes ($> 0.5\%$ of measuring range)	71,0 %
Resistance thermometers Pt 100 DIN	70,6 %
Thermocouples	70,70 %

Field indicators:

Pressure gauges	71,6 %
Pressure gauges (flanged connections)	72,0 %
Liquid expansion thermometers	71,0 %
Bimetal thermometers	72,0 %

Flow meters ($> 1\%$ of measuring range)

Magnetic flow meters	71,0 %
Turbine flow meters	70,0 %
Positive displacement meters	70,0 %
Rotameters	71,6 %
Rotameters with PTFE lining	72,0 %
Rotameters (for purge systems)	74,0 %
Coriolis flow meters for gas streams	(*)70,0 %
Coriolis flow meters for liquid streams	(*)70,2 %
Vortex flow meters for gas or vapour streams	(*)71,0 %
Vortex flow meters for liquid streams	(*)71,0 %
Thermal mass flow meters	(*)72,0 %

(*) accuracy rating referred to the measured value

Transmitters

Temperature transmitters for resistance Thermometers/thermocouples	70,6 %
Pressure transmitters	70,2 %
Differential pressure transmitters	70,2 %
Level transmitters (displacer type)	71,0 %
Level transmitters (radar type)	710 mm 70,3 %

I/P transducers	70,6 %
A/D or D/A converters	70,2 %

Control room instruments

Line recorders	70,0 %
Dotted line recorders	70,0 %
Pneumatic indicators	70,0 %
Electric indicator	70,0 %
Factors influencing the measuring accuracy:	



1. FLOW INSTRUMENTS

1.1. ORIFICE PLATES

In general, flow measurement will be made by means of square-edged concentric orifice plates mounted between flanges with flange taps, in accordance with ISO 5167 recommendations and relevant codes and standards.

Eccentric orifices may be used in horizontal lines to avoid accumulation of liquid when vent or drain holes (maximum 3 mm diameter) are not specified or with fluids containing solids. Quarter circle or conical entrance orifice plated may be selected when a square-edge type is not appropriate.

Orifice plates shall be in AISI 316 as minimum for general service. Other materials shall be used when AISI 316 is not suitable for the service conditions; The material to be used will be specified on Piping material specification and/or instrument data sheet.

Orifice plate beta ratios shall be between 0.2 to 0.7.

Orifice meter runs shall be used for line size lower than 2".

Integral Orifice assemblies shall be used for to measure flow rates which can't be measured accurately with the minimum size of meter runs.

Orifices will be sized for the following standard instrument DP range:

- 12, 5, 25, 50, 72, 5, 125, 250, 500, 1000, 1250 mbar.

In order to achieve a minimum pressure loss in the system, the maximum allowable beta value (d/D) will be selected for each orifice.

Straight run pipe requirements shall be in accordance with ISO 5167 or vendor requirements. Straightening vane can be used to reduce upstream pipe lengths.

1.2. VENTURI AND FLOW NOZZLE

Venturi tubes may be selected for non-viscous fluids when relatively high accuracy is required with a low-pressure drop in the system and or short minimum straight run piping requirements.

1.3. PITOT TUBES

Pitot tubes or modified pitot tubes (Annubars) may be selected for large flows of clean fluid to achieve minimum pressure loss in the system where the pressure drop through an orifice is uneconomical or flow measurement accuracy is not critical.

1.4. MAGNETIC FLOW METERS

Magnetic flow meters may be used for dirty liquids having conductivity higher than 50 µS/cm.

1.5. VORETX FLOW METERS

Vortex and other non differential flow transmitters shall be used only in special applications as shown on P&IDs.

1.6. MASS FLOW METERS

Generally, Coriolis or thermal Mass flow meters shall be used for mass flow measurement. Installation of flow meters shall be in a manner as to ensure that the entire assembly is fitted with the respective process fluid.



10.7 DIFFERENTIAL PRESSURE TRANSMITTERS

Flow measurement signals (e.g. for indication/recording / totalizing / trending etc.) will generally be connected to the DCS:

Transmitter measuring principles used with orifice plates, venturi tubes, pitot tubes, etc. will be in accordance with the selected manufacturer's standards e.g. diffused silicon strain gauge, capacitance etc....

The transmitters will be of the "smart" type (HART Protocol) with accuracy better than 0.2%. The sensing element material will be AISI 316 minimum.

Electronic transmitters will be furnished with test terminals and by-pass diode to facilitate field testing without disconnection or connection of a field mounted signal indicator (MV-Meter) either integral with or remote from the transmitter. Transmitters shall be reverse polarity protected.

10.8 FLOW SWITCHES

Direct-acting flow switches will not generally be used for process fluids. Switch actions will normally be made via normal measuring means with the switch function on the transmitter output or as threshold contact type on local flow indicator.

The switch function will be adjustable. Switches will have changed-over volt-free snap-acting contacts.

Further detailed data and information will be provided when specifying the instruments

10.9 LOCAL FLOW MEASUREMENT:

For local measurement, variable flow meters or differential head type elements with DP pressure indicator will be used.

10.10 P/T COMPENSATION:

Whenever high fluctuation of pressure or temperature of the process fluids are expected, P/T compensation shall be considered.

11 LEVEL INSTRUMENTS

11.1 DISPLACEMENT TYPE

External displacer-type (torque tube type) transmitters will generally be used for level ranges lower than or equal to 1219 mm (48"). Adequate valves will be provided for maintenance purposes.

The following standard ranges will be used:

- 306, 813, 1219, 1524, 1829, 2134: mm
- 12, 32, 48, 60, 72, 84: inch

Displacement type level instrument shall not be used with viscous, turbulent, solidifying, corrosive conditions or liquids that boils at ambient temperature.



Internal displacer type (displacer hanging in vessel) will only be used where conditions dictate that the level shall be measured internally and where turbulence will not detach the displacer. and they shall be avoided practically on vessels that can't be isolated without shutting down a part of the plant.

Extensions will be considered for services above 200°C (fins).

Connections will be in general side-bottom mounted. The housing will be rotatable. Left-hand type or right-hand mounting position of housing will be in accordance with the installation requirements. Drain valves shall be considered for external level transmitters.

11.2 DIFFERENTIAL PRESSURE TYPE

In general, differential pressure transmitters will be used to measure liquid level where the range of level to be measured is greater than 2000 mm and where this type of instrument is preferred to a displacer type like steam drum level.

Transmitter measuring principles will be in accordance with the selected manufacturer's standards, and preferably same as those differential pressure transmitters used for flow measurement.

External differential pressure instruments shall be installed lower than the lowest vessel connection and higher than the highest vessel connection depending on the process fluid or selected purge method.

The transmitters will be of the "smart" type with accuracy better than 0.2%. The sensing element material will be AISI 316 minimum.

Electronic transmitters will be furnished with test terminals and by-pass diode to facilitate field testing without disconnection or connection of a field mounted signal indicator (MV-Meter) either integral with or remote from the transmitter. Transmitters will be reverse polarity protected. D/p transmitters will have zero elevation or suppression as required.

11.3 DIAPHRAGM SEAL AND CAPILLARIES

For measurement of viscous fluids, fluids containing solids, highly corrosive fluids or where temperature changes may influence the fluid conditions, the use of diaphragm seals and capillaries may be considered. Capillaries for remote seal applications will be kept as short as possible and will not exceed 6 m. When remote seal systems are specified, the fill liquid shall be selected to agree with the process requirements, and shall not affect a change in the instrument calibration when subjected to a calibration at ambient conditions versus normal process condition.

11.4 LIQUID LEVEL SWITCHES

Depending on the process requirements, level switches shall be of the float type, tuning fork, or capacitive sensor type. Switches without mechanical contacts are preferred. For process connection refer to the Table #1 on the attachment.

11.5 SPECIAL LEVEL MEASUREMENTS:

Capacitive level transmitters may be used as an alternative for fluids of high viscosity and for bulk materials.

Ultrasonic or radar methods will be used for tank gauging if physical condition of the process fluid allows this.

Radioactive level measurements will be used in the polymerization reactors only, as in this case it is the only possible method of measurement.



Load cell assemblies normally will be used for silo measurement. In that case the silo shall be installed stress free.

11.6 LOCAL LEVEL INDICATORS:

Local level indicators with all metric construction and magnetic coupling of follower magnet is generally preferred. For process connection refer to Table #1.

The instruments will have vents and drains according to manufacturers standard. In justified exceptional cases and as explicit shown on the PID, permanently attached valves and fluid discharge lines will be used and installed in accordance with the piping specification.

Local tank level gauges with a large measuring range will consist of level transmitters with local indicators.

11.7 REMARKS

- There will be no local recording
- Installing two or more devices on the same connections will be avoided.

12 PRESSURE INSTRUMENTS

12.1 GENERAL

Pressure-measuring elements will be minimum AISI 316 stainless steel or comply with piping material if more resistive material required.

Pressure Instruments will have over-range protection to minimize the effect of over pressure in order to avoid a shift in calibration. Instruments, which can be exposed to vacuum, will have under range protection. Over-range protection will cover the Design pressure of line.

Pulsation dampeners or glycerin-filled systems will be supplied for all pressure instruments and gauges in vibrating or pulsating services.

Differential-pressure instruments will generally be capable of withstanding the full static pressure without loss of calibration.

For the measurement of absolute pressure, differential pressure transmitters will be used with an absolute vacuum reference chamber.

12.2 PRESSURE GAUGES

Bourdon-tube type pressure gauges will generally be used. The material of the Bourdon-tube will be SS 316 minimum or better, depending on process requirements.

Pressure gauges shall have stainless steel housings with a blowout disc and zero adjustment. It must be possible to fill the gauge with glycerin.

The movement will be of corrosion and wear-resistant material, e.g. stainless steel/nylon-coated, independent of case.

Gauges for direct mounting will have a 1/2" NPT male bottom connection and a 4" (100 mm) dial.

Bourdon tube type pressure gages shall be used for ranges from 1 Barg to 100 Barg

Diaphragm type pressure gages shall be used for measuring ranges bellow 1 Barg.



Over range protection of pressure gauges shall be 1.3 of full scale.



For slurry, viscous, highly corrosive or fluids with suspended solids the pressure gages shall have diaphragm seal with 1/2" flange connection.

Pressure gauges will preferably be direct-mounted to the process. Receiver gauges may be local field-mounted or panel-mounted (local panel).

12.3 PRESSURE SWITCHES

Pressure switches will be of the Bourdon tube or pressure gauges with adjustable contacts (proximity type), diaphragm or bellows type with a 316 SS element as a minimum requirement. Switches will be adjustable over the full scale. Pressure switches for direct mounting will have a 1/2" NPT female connection. Diaphragm seals with capillary shall be provided where required. Whenever no suitable pressure switch can be found due to material or, over-range protection requirements etc., a 4 - 20 mA electronic transmitter will be used instead. Pressure switches for pneumatic signals will preferably have bellows measuring elements. Connections will be 1/4" NPT female. Pressure switches will have a minimum standard over-range protection of 120% of range and be capable of withstanding the full static design pressure of the system without loss of calibration. Switches will be snap acting hermetically sealed switches with contact rating in accordance with IEC 947-5-1 and relevant codes and standards. The switches type shall be SPDT type.

12.4 TRANSMITTERS

Transmitter measuring principles will be in accordance with the selected manufacturer's standards e.g. diffused silicon strain gauge, capacitance etc.

The transmitter will be of the "smart" (HART protocol) type with accuracy better than 0.2%.

The sensing element material will be AISI 316 minimum.

Electronic transmitters will be furnished with test terminals and by-pass diode to facilitate field-testing without disconnection or connection of a field mounted signal indicator (MV-Meter) either integral with or remote from the transmitter. Transmitters will be reverse polarity protected.

Electronic transmitters will have a provision for checking zero and span on the output terminals while the transmitter is in service.

The manufacturer of each type of transmitter shall supply suitable communicator.

12.5 DIAPHRAGM SEALS AND CAPILLARIES

For measurement of viscous fluids, fluids containing solids, highly corrosive fluids or where temperature changes may influence the fluid conditions the use of remote diaphragm seals and capillaries may be considered. Capillaries for remote seal applications will be kept as short as possible and will not exceed 1 m in length.

Seals and capillaries will be considered to be an integral part of the instrument.



13 TEMPERATURE INSTRUMENTS

13.1 THERMOWELLS

Standard length thermowells will be used. Thermowell will be solid machined and drilled from bar stock. They will be selected in accordance with the piping class.

Thermowells shall be flanged type, for connection size refer to Table #1.

13.2 THERMOCOUPLE ELEMENTS (T/C'S)

Thermocouples will be in accordance with IEC-60584; non-grounded hot junction type will be used for temperature measurement. RTD detectors will be used in preference to thermocouples for temperature ranges of -200 to 600°C . The following types of thermocouples may be used depending on the temperature range to be measured.

- Type K (chromel - alumel) -270 to 1372°C (Nickel-chrome/nickel-aluminum)
- Type R (platinum 13% rhodium-platinum) -50 to 1768°C
- Standard length thermocouples will be used. Thermocouple inserts will match the standard Thermowell diameter and length. Lagging extensions will be supplied as required. Connection heads to be metal type.
- Stainless steel sheathed mineral-insulated spring-loaded 2-wire type elements will be used. Special protection tube/sheathing and/or insulation will be used for temperatures above 400°C , saline environment and when hydrogen diffusion may be expected.
- For services where thermowells must be considered to be an obstacle in the process (clogging/turbulence), skin-type thermocouples may be considered. Skin-type thermocouples will be used to measure heater coil, reactor wall temperatures, as per process. Skin-type thermocouples will preferably be welded to the surface and as a minimum be spring-loaded or clamped. Open-air skin-thermocouple installations will be insulated. Skin-type thermocouples will not generally be used for shutdown purposes.

13.3 RESISTANCE-TYPE ELEMENTS (RTD'S)

Platinum-type resistance elements, with characteristics in accordance with IEC 60751 (resistance 100 ohms at 0°C), will be used in preference to thermocouples for ranges between of -200 to 600°C

- Standard length elements will be used. RTD inserts will match the standard Thermowell diameter and length. Lagging extensions will be supplied as required. Connection heads to be metal type.
- Stainless steel sheathed mineral-insulated spring-loaded 3-wire type elements will be used.

13.4 THERMISTOR AND SEMICONDUCTOR SYSTEMS

These systems will not be used, except for motor windings when specified.

13.5 BIMETALLIC SYSTEMS

Dial thermometers for local use will be of the bimetallic type with adjustable gland and dial. Dial thermometers will fit the standard Thermowell diameter and lengths.



Thermometers will be heavy duty, industrial type. Nominal dial size will be 100 mm (4"). Case to be stainless steel with back shafts and zero adjustment. The movement will be of corrosion and wear-resistant material, e.g. stainless steel/nylon-coated, independent of the housing. Bimetallic-operated switches may only be used in non-critical services such as for tank heater. Bimetallic switches are not permitted for process alarm and shutdown functions.

13.6 TRANSMITTERS

- Head mounted mV/I (T/C) or ohm/I (RTD) converters will be used as much as possible. The required degree of accessibility will be strictly adhered to.
- In cases head mounting is not possible or when indicator is required, where, the converter will be installed locally, close to the measuring element or in the place where local reading is required.
- Cold junction compensation will be provided for mV/I (T/C) converters. Transmitters will be of the "smart" type with accuracy better than 0.2%. Electronic transmitters will be furnished with test terminals and by-pass diode to facilitate field-testing without disconnection or connection of a field mounted signal indicator (MV-Meter) either integral with or remote from the transmitter. Transmitters will be reverse polarity protected. Electronic transmitters will have a provision for checking zero and span on the output terminals while the transmitter is in service.

13.7 SPECIAL APPLICATIONS

Temperature-measurement on rotating equipment:

- A temperature rise in the bearings of rotating machinery, is an indication of approaching problems.
- In thrust bearing, a temperature rise indicates inadequate cooling of bearings or excessive wear.
- Sensors, extension wire, terminal heads, cables, boxes, etc., must be capable of withstanding considerable mechanical stress, weather exposure, fire-protection sprinklers, equipment washing etc.

13.8 REMARKS

Local temperature control (thermo-valve) is not recommended. Local recording will not be done.

Further detailed data and application for each type of instrument will be provided when specifying the temperature instruments.



14. CONTROL VALVES

14.1. GENERAL REQUIREMENT

Supplier quotation shall include a detailed specification sheet for each control valve, which shall provide all the details regarding type, construction materials, noise, etc... and any other valve accessories.

This specification is general. If exceptions, variation or additions are required in individual cases they will be shown on specification/data sheets for control valves.

Any proposed deviation from control valve specification /data sheets or this general specification, must be approved in writing by client / contractor.

14.2. CONTROL VALVES SELECTION

14.2.1. Required valves capacities

Required valve capacities shall be referred to in terms of CV coefficients and selected CV value.

14.2.2. Valve sizing

A calculation note / sheet for the sizing of each control valve shall be supplied.

Calculation of the control valves shall be based on ISA S 75.1 "Control valve sizing equations".

The control valve capacities in term if CV shown on the purchaser's data sheets has been arrived at using the formula given in the standard ISA-S-75.1, "Control Valve Sizing Equations". In case of Vendor sizing formula differs from this. Purchaser should be provided with the same.

In general, control valves shall be sized so that the valve opening is as following:

At maximum flow-about 90% open

At normal flow about 70% open

At minimum flow about 20% open

Rangeability of valves shall be 30:1 unless otherwise specified.

Butterfly valves shall be sized assuming a 60° opening at max. flow in general.

Non preferred valve body sizes are 1/4", 3/4", 1 1/2", 2 1/2", 4 1/2", 6", 8" and 9".

Vendor shall furnish calculation sheets or computer print out for sizing.

14.2.3. By pass & Block Valve

Block & Bypass valves are mostly manifolded in piping system to allow manual manipulation of flow through systems when control valves are not in service. Bypass valves in sizes of 2 inches or less most be globe valves.

They should have a capacity at least equal to the calculated Cv of control valve.

Block and Bypass valves should be avoided in the following cases:

- On hydrogen service
- Around 3-way valves
- Around self-acting steam pressure reducing valves
- Around control valves forming part of a protection system



14.2.4. Valve type

Globe body type control valves shall generally be chosen for standard use (due to bench test requirement).

Butterfly control valves shall be considered where:

- When available pressure drop is low
- For large line sizes
- Where allowed in piping specification

Shut off valves shall be generally selected as Ball type except for high temperature services.

Valves using special technology shall be submitted to the Client / Contractor for approval. (Clearly noted on P&ID)

For small size or special cases (low noise, etc...) other types shall also be considered

14.3. GENERAL VALVE CONSTRUCTION REQUIREMENTS

14.3.1. Flange Finish Facing

Minimum body and connection rating shall be 300 lbs Raised Face (RF). Flange facing shall be chosen in accordance with classes of the piping specification. Contact finish facing shall be as follows:

Spiral serrated finish (conventional symbols: RFD)

Roughness: Ra 6.3 μm to 12.5 μm (250 μin to 500 μin AARH)

Smooth finish (conventional symbols: RFC)

Roughness: Ra 3.2 μm to 6.3 μm (125 μin to 250 μin AARH)

For RTJ flanges, ring joints will be supplied by others

14.3.2. Accessories

Limit switches if any shall be proximity type with NAMUR standard.

All control valves shall be normally fitted with an electropneumatic positioners.

All accessories specified on data sheets shall be supplied, installed, connected and wired to the valve by the valve supplier.

All tubing shall be in 316 Stainless steel.

Compression fittings shall be in SS 316 Stainless steel double ferrule design.

Pneumatic connections shall be 1/4" NPT female minimum, or bigger if stated by supplier for flow considerations.

Electrical connections shall be:

- M20 x 1.0 ISO for positioner
- M20 x 1.0 ISO solenoid valve

All positioners shall have pneumatic gauges, graduated in bar, two (2) in case of electropneumatic positioners, three (3) in case of pneumatic positioners if any. Dial size shall be as per Vendor standard.

Solenoid valves shall be provided where specified on data sheets and shall be NAMUR type.

Valve trim shall be stainless steel with Viton or similar resilient seat to provide tight shutoff.

Solenoid valves shall be normally energized. Coils shall be suitable for permanent energizing.

Low power coils shall be proposed (maximum acceptable is 10 W). Electrical power for solenoid valves coils will be 24 VDC.

Solenoid valves shall be suitable for instrument air Service.



When specified, solenoid valves shall be provided with manual reset facilities. The manual reset facilities shall prevent automatic reset but allow local manual reset of individual valves on restoration of electrical power (i.e. reset of electrical logic), and local shutdown.

15. PRESSURE RELIEF VALVES

Pressure relief valves shall be full-bore type.

Relief valves shall be designed in accordance to the requirements of API-RP-597.

Lifting lever shall be provided for steam and air services.

Conventional valves shall be used for constant back pressure applications while pressure balanced valves with stainless steel bellows shall be used for varying back pressure application where the back pressure exceeds 10% of the set pressure of the valve.

Connection of Pressure relief valves shall be flanged type while the connections of thermal relief valves shall be screwed type.

Steel bodies with stainless steel trim shall be used for all pressure relieving devices unless piping specification requires alloy construction.

Rupture Disc may be used in lieu of or in combination with safety and relief valves.

Combination of rupture disc and pressure safety valve shall be used for slurry or highly corrosive services.

Rupture discs shall be provided with bursting alarm device. Combination of rupture disc and relief valves shall include a pressure switch installed between disc and valve to alarm a leakage or burst.

16. ANALYZERS

Process analyzers requiring sampling will be supplied pre-assembled with their own sampling and conditioning systems in open ladder type racks. Analyzer racks will be installed in analyzer houses.

Where possible analyzers will be of the on-line type.

When necessary analyzers will be provided with a fast loop system

Sample purge gas and analyzer vent gas will be properly vented to a safe area.

When applicable analyzer transmitters shall be of the "smart" type with accuracy better than 0.2% and have a 4-20 mA output to DCS.

All materials used shall be suitable for the sample stream and the surrounding atmosphere; AISI 304 / 316 shall be selected as minimum.

Whenever practical sample shall be returned to the process. Other methods of disposal shall ensure safety and pollution restrictions.

Field mounted analyzers shall be used for simple analyzers such as Conductivity, PH, density, etc.

Analyzers shall be in general installed in analyzer house that shall be weather proof, with air conditioning.

Sample Pressure reducers, conditioners, fast loops, and calibration gas cylinders shall be installed outside analyzer house.



Further detailed data and application for each type of analyzer will be provided when specifying the analyzers.

INSTRUMENT ON VESSEL	VESSEL CONNECTION	FIRST BLOCK VALVE	INSTRUMENT CONNECTION
External level instrument	2" flanged	2" flanged	2" flanged
Internal displacer level	4" flanged	-	-
External ball float level switch	4" flanged	-	4" flanged
Internal ball float level switch	4" flanged	-	4" flanged
Level guage on vessel	1" flanged	1" flanged	1" flanged
Level guage on standpipe	1" flanged	1" flanged	1" flanged
Magnetic level instrument	1" flanged	1" flanged	1" flanged
Dp cell on vessel (without diaphragm)	1" flanged	1" flanged	1/2" NPT
Dp cell on vessel (with diaphragm)	3" flanged	3" flanged	3" diaph.seal
Dp cell on standpipe(without diaphragm)	1" flanged	1" flanged	1/2" NPT
Dp cell on standpipe (with diaphragm)	3" flanged	3" flanged	3" diaph.seal
Dip tube level instrument	4" flanged	1" flanged	1/2" NPT
Pressure guage&transmitter(general case)	1" flanged	1" flanged	1/2" NPT
Pressure transmitter with diaphragm	2" flanged	2" flanged	2" flanged
Pressure gauge with diaphragm	2" flanged	2" flanged	2" flanged
Thermowell (general case)	1 1/2" flanged	-	-
D/P pressure transmitter /gauge(vessel)	1" flanged	1" flanged	1/2" NPT
Radar type level instrument	3" flanged	-	-

Table #1

PIPING	PIPE CONNECTION	FIRST BLOCK PIPE	INSTRUMENT CONNECTION
Orifice (Dp) flow-meter	1/2"	1/2"	1/2" NPT
Pitot tube	Acc.mfr.std	Acc.mfr.std	1/2" NPT
Pressure transmitter	1/2"	1/2"	1/2" NPT
Pressure gauge	1/2"	1/2"	1/2" NPT
Pressure transmitter with diaphragm	2" flanged	2" flanged	2" flanged
Pressure gauge with diaphragm	2" flanged	2" flanged	2" flanged
Thermowell (flanged connection)	1 1/2" flanged	-	TE : 1/2" NPT
Thermowell (Threaded connection)	1" NPT	-	
Analyzer connection	1" flanged	Special valve	Acc.mfr.std
D/P pressure transmitter/gauge	1/2"	1/2"	1/2"

Table #2

PROJECT: PP-PE PILOT PLANT

DATA SHEET FOR ON-OFF/PISTON VALVE



شرکت ملی صنایع پتروشیمی
شرکت پژوهش و فناوری پتروشیمی

Contractor Job No:

Doc. No:

Owner Job No:

Sheet No. :

of

Valve (HV)	Item		HV 2501	
	Service		R251 to BDL	
	Location		LOCAL	
	P&I n.		312002_025	
	Fluid		SLURRY	
	State		LIQUID	
	Condition	Normal Pressure	Barg	28
		Normal DP	Barg	38
		Max Pressure	Barg	45
		Normal Temp.	°C	20
		Max. Temp.	°C	-60 +180
	Flowrate	Normal	Kg/h	
		Minimum	Kg/h	0
		Full Scale	Kg/h	0
	Sp. Gr.	Gas vapurs	Kg/m3	
		Liquid	Kg/m3	
		Mol. Weight	Kg/Kmol	
		Viscosity	mPa's	
	Type		REDUCE BORE RAM PISTON VALVE - Flanged - Raised Face	
	Size		1" ($\varnothing=1/2$ ")	
	Rating		ANSI #600	
	Fire Safe Seat		YES	
	Body material + Trim Material + stem Material		forged S.Steel 316	
	Valve Seat		Metal to metal seated valves	
Valve Seat material		316 SS		
SEAL		VTA(soft seal & cover & rod guide)		
MANUFACTURER		VTA		
MODEL no.		VTA		
Ordering code information		VTA		
Certificates & Calibration		pressure test, inspection certificate-Works		
accessary		Marking(Tagging)		

		PROJECT: PP-PE PILOT PLANT		 شرکت ملی صنایع پتروشیمی شرکت پژوهش و فناوری پتروشیمی
		DATA SHEET FOR ON-OFF/PISTON VALVE		
		Contractor Job No:	Doc. No:	
		Owner Job No:	Sheet No. :	of
Pneumatic Piston+Cylinder Actuator	Type of Actuator		Pneumatic Piston+Cylinder	
	Actuator size		VTA	
	Actuator ANGLE (torque)		directly	
	Acting = Spring Return or Double Acting Type		Spring Return (SINGOL ACTION)	
	Air supply press. Barg		6	
	On Air Failure		OPEN	
	Manual Hand wheel + Declutched or Side type		YES (Manual Hand wheel + Declutched)	
	Body material		VTA (lightweight or Aluminium Body)	
	Valve position monitor		YES	
	Air filter regulator + Supply & output pressure gauge		YES	
	MANUFACTURER		VTA	
	MODEL no.		VTA	
	Ordering code information		VTA	
accessary		Marking(Tagging)		
Solenoid	Solenoid Valve Type		3-way solenoid valve	
	Power Supply V DC		24 V DC, power consumption 26.71 mW	
	ENCLOSURE PROTECTION		EE xia , IIC , T6	
	Mounting Position (Remote version or copmact)		Remote version (conection with tube)	
	single actuated with spring return mechanism		YES	
	double actuated with two locking positions		NO	
	On Power Failure		open ways actuator and exhaust and air inside actuator discharges	
	Threaded connection Size		(NPT) 1/2 or (NPT) 1/4	
	Degree of protection		IP 65 with filter check valve	
	Output current (mA)		≥ 1.6 mA	
	Electrical connection		M20 & 1.5	
	MANUFACTURER		VTA	
	Ordering code information		VTA	
accessary		Marking(Tagging)		
Limit Switch Or Proximity Sensor	Type	Quantity	Proximity Sensor - Namur	2 = For close & open
	Power Supply V DC		8 V DC	
	ENCLOSURE PROTECTION		EE xia , IIC , T6	
	Degree of protection		IP 65	
	Electrical connection		M20 & 1.5	
	MANUFACTURER		VTA	
	Ordering code information		VTA	
	accessary		two Safety Barrier	

PROJECT: PP-PE PILOT PLANT		 شرکت ملی صنایع پتروشیمی شرکت پژوهش و فناوری پتروشیمی
DATA SHEET FOR ON-OFF/PISTON VALVE		
Contractor Job No:	Doc. No:	
Owner Job No:	Sheet No. :	of

PAD 1" 600#

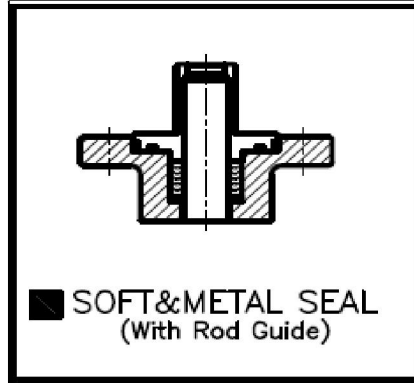
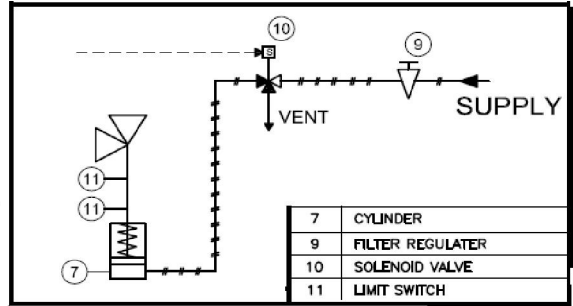
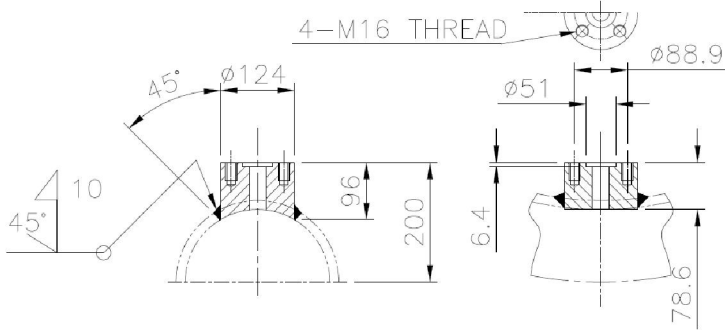

10/10/2021	AFC	K.A/ V.V	M.N	01	M.A
Date	Status	Prepared	Checked	Rev.	Approved

		PROJECT: PP-PE PILOT PLANT		 شرکت ملی صنایع پتروشیمی شرکت پژوهش و فناوری پتروشیمی	
		DATA SHEET FOR ON-OFF/PISTON VALVE			
Contractor Job No:		Doc. No:			
Owner Job No:		Sheet No. : of			
Valve (HV)	Item	HV 2502			
	Sevice	R251 to CY251			
	Location	LOCAL			
	P&I n.	312002_025			
	Fluid	SLURRY			
	State	LIQUID			
	Condition	Normal Pressure	Barg	28	
		Normal DP	Barg	38	
		Max Pressure	Barg	45	
		Normal Temp.	°C	20	
		Max. Temp.	°C	-60 +180	
	Flowrate	Normal	Kg/h		
		Minimum	Kg/h	0	
		Full Scale	Kg/h	0	
	Sp.Gr.	Gas vapurs	Kg/m3		
		Liquid	Kg/m3		
		Mol. Weight	Kg/Kmol		
		Viscosity	mPa's		
	Type	REDUCE BORE RAM PISTON VALVE - Flanged - Raised Face			
	Size	1" (Ø=½")			
	Rating	ANSI #300			
	Fire Safe Seat	YES			
	Body material + Trim Material + stem Material	forged S.Steel 316			
	Valve Seat	Metal to metal seated valves			
	Valve Seat material	316 SS			
	SEAL	VTA(soft seal & cover & rod guide)			
	MANUFACTURER	VTA			
	MODEL no.	VTA			
Ordering code information	VTA				
Certificates & Calibration	pressure test, inspection certificate-Works				
accessary	Marking(Tagging)				

PROJECT: PP-PE PILOT PLANT

DATA SHEET FOR ON-OFF/PISTON VALVE



شرکت ملی صنایع پتروشیمی
شرکت پژوهش و فناوری پتروشیمی

Contractor Job No:

Doc. No:

Owner Job No:

Sheet No. : of

Pneumatic Piston+Cylinder Actuator

Type of Actuator	Pneumatic Piston+Cylinder
Actuator size	VTA
Actuator ANGLE (torque)	directly
Acting = Spring Return or Double Acting Type	Spring Return (SINGOL ACTION)
Air supply press. Barg	6
On Air Failure	OPEN
Hand wheel + Declutched or Side type	YES (Hand wheel + Declutched)
Body material	VTA (lightweight or Aluminium Body)
Valve position monitor	YES
Air filter regulator + Supply & output pressure gauge	YES
MANUFACTURER	VTA
MODEL no.	VTA
Ordering code information	VTA
accessary	Marking(Tagging)

Solenoid

Solenoid Valve Type	3-way solenoid valve
Power Supply V DC	24 V DC, power consumption 26.71 mW
ENCLOSURE PROTECTION	EE xia , IIC , T6
Mounting Position (Remote version or copmact)	Remote version (conection with tube)
single actuated with spring return mechanism	YES
double actuated with two locking positions	NO
On Power Failure	open ways actuator and exhaust and air inside actuator discharges
Threaded connection Size	(NPT) 1/2 or (NPT) 1/4
Degree of protection	IP 65 with filter check valve
Output current (mA)	≥ 1.6 mA
Electrical connection	M20 & 1.5
MANUFACTURER	VTA
Ordering code information	VTA
accessary	Marking(Tagging)

Limit Switch Or Proximity Sensor

Type	Quantity	Proximity Sensor - Namur	2 = For close & open
Power Supply V DC		8 V DC	
ENCLOSURE PROTECTION		EE xia , IIC , T6	
Degree of protection		IP 65	
Electrical connection		M20 & 1.5	
MANUFACTURER		VTA	
Ordering code information		VTA	
accessary		two Safety Barrier	

PROJECT: PP-PE PILOT PLANT

DATA SHEET FOR ON-OFF/PISTON VALVE



شرکت ملی صنایع پتروشیمی
شرکت پژوهش و فناوری پتروشیمی

Contractor Job No:

Doc. No:

Owner Job No:

Sheet No. :

of

PAD 1" 600#

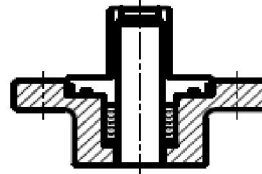
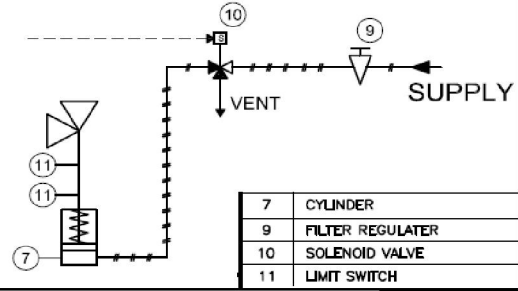
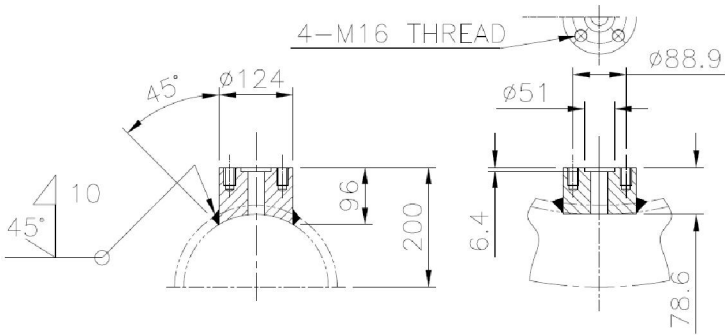

SOFT & METAL SEAL
(With Rod Guide)

10/10/2021	AFC	K.A/ V.V	M.N	01	M.A
Date	Status	Prepared	Checked	Rev.	Approved

PROJECT: PP-PE PILOT PLANT

DATA SHEET FOR ON-OFF/PISTON VALVE



شرکت ملی صنایع پتروشیمی
شرکت پژوهش و فناوری پتروشیمی

Contractor Job No:

Doc. No:

Owner Job No:

Sheet No. :

of

Valve (HV)	Item		HV 2601	
	Service		R261 to BDL	
	Location		LOCAL	
	P&I n.		312002_026	
	Fluid		SLURRY	
	State		LIQUID	
	Condition	Normal Pressure	Barg	28
		Normal DP	Barg	38
		Max Pressure	Barg	45
		Normal Temp.	°C	20
		Max. Temp.	°C	-60 +180
	Flowrate	Normal	Kg/h	
		Minimum	Kg/h	0
		Full Scale	Kg/h	0
	Sp. Gr.	Gas vapurs	Kg/m3	
		Liquid	Kg/m3	
		Mol. Weight	Kg/Kmol	
		Viscosity	mPa's	
	Type		REDUCE BORE RAM PISTON VALVE - Flanged - Raised Face	
	Size		1" ($\varnothing=3/2"$)	
	Rating		ANSI #600	
	Fire Safe Seat		YES	
	Body material + Trim Material + stem Material		forged S.Steel 316	
	Valve Seat		Metal to metal seated valves	
Valve Seat material		316 SS		
SEAL		VTA(soft seal & cover & rod guide)		
MANUFACTURER		VTA		
MODEL no.		VTA		
Ordering code information		VTA		
Certificates & Calibration		pressure test, inspection certificate-Works		
accessary		Marking(Tagging)		

		PROJECT: PP-PE PILOT PLANT		 شرکت ملی صنایع پتروشیمی شرکت پژوهش و فناوری پتروشیمی
		DATA SHEET FOR ON-OFF/PISTON VALVE		
		Contractor Job No:	Doc. No:	
		Owner Job No:	Sheet No. :	of
Pneumatic Piston+Cylinder Actuator	Type of Actuator		Pneumatic Piston+Cylinder	
	Actuator size		VTA	
	Actuator ANGLE (torque)		directly	
	Acting = Spring Return or Double Acting Type		Spring Return (SINGOL ACTION)	
	Air supply press. Barg		6	
	On Air Failure		OPEN	
	Manual Hand wheel + Declutched or Side type		YES (Manual Hand wheel + Declutched)	
	Body material		VTA (lightweight or Aluminium Body)	
	Valve position monitor		YES	
	Air filter regulator + Supply & output pressure gauge		YES	
	MANUFACTURER		VTA	
	MODEL no.		VTA	
	Ordering code information		VTA	
accessary		Marking(Tagging)		
Solenoid	Solenoid Valve Type		3-way solenoid valve	
	Power Supply V DC		24 V DC, power consumption 26.71 mW	
	ENCLOSURE PROTECTION		EE xia , IIC , T6	
	Mounting Position (Remote version or compact)		Remote version (connection with tube)	
	single actuated with spring return mechanism		YES	
	double actuated with two locking positions		NO	
	On Power Failure		open ways actuator and exhaust and air inside actuator discharges	
	Threaded connection Size		(NPT) 1/2 or (NPT) 1/4	
	Degree of protection		IP 65 with filter check valve	
	Output current (mA)		≥ 1.6 mA	
	Electrical connection		M20 & 1.5	
	MANUFACTURER		VTA	
	Ordering code information		VTA	
accessary		Marking(Tagging)		
Limit Switch Or Proximity Sensor	Type	Quantity	Proximity Sensor - Namur	2 = For close & open
	Power Supply V DC		8 V DC	
	ENCLOSURE PROTECTION		EE xia , IIC , T6	
	Degree of protection		IP 65	
	Electrical connection		M20 & 1.5	
	MANUFACTURER		VTA	
	Ordering code information		VTA	
	accessary		two Safety Barrier	

PROJECT: PP-PE PILOT PLANT		 شرکت ملی صنایع پتروشیمی شرکت پژوهش و فناوری پتروشیمی
DATA SHEET FOR ON-OFF/PISTON VALVE		
Contractor Job No:	Doc. No:	
Owner Job No:	Sheet No. :	of

PAD 1" 600#

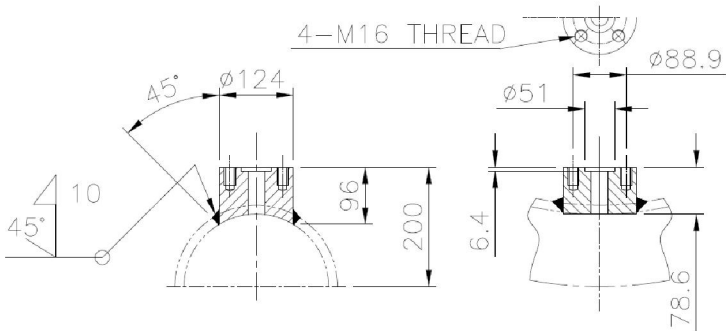

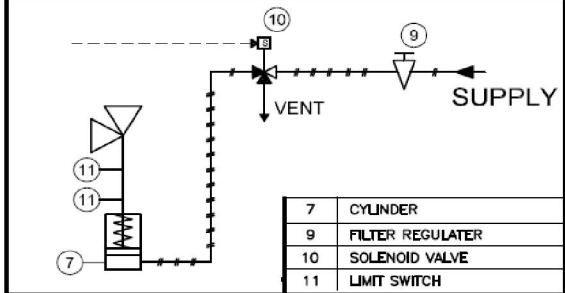

7	CYLINDER
9	FILTER REGULATOR
10	SOLENOID VALVE
11	LIMIT SWITCH

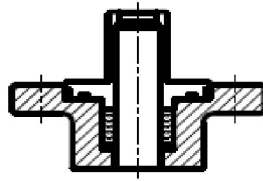

SOFT&METAL SEAL
(With Rod Guide)

10/10/2021	AFC	K.A/ V.V	M.N	01	M.A
Date	Status	Prepared	Checked	Rev.	Approved

PROJECT: PP-PE PILOT PLANT

DATA SHEET FOR ON-OFF/PISTON VALVE



شرکت ملی صنایع پتروشیمی
شرکت پژوهش و فناوری پتروشیمی

Contractor Job No:

Doc. No:

Owner Job No:

Sheet No. :

of

Valve (HV)	Item		HV 2602	
	Service		R261 to CY261	
	Location		LOCAL	
	P&I n.		312002_026	
	Fluid		SLURRY	
	State		LIQUID	
	Condition	Normal Pressure	Barg	28
		Normal DP	Barg	38
		Max Pressure	Barg	45
		Normal Temp.	°C	20
		Max. Temp.	°C	-60 +180
	Flowrate	Normal	Kg/h	
		Minimum	Kg/h	0
		Full Scale	Kg/h	0
	Sp. Gr.	Gas vapurs	Kg/m3	
		Liquid	Kg/m3	
		Mol. Weight	Kg/Kmol	
		Viscosity	mPa's	
	Type		REDUCE BORE RAM PISTON VALVE - Flanged - Raised Face	
	Size		1" (Ø=1/2")	
	Rating		ANSI #300	
	Fire Safe Seat		YES	
	Body material + Trim Material + stem Material		forged S.Steel 316	
	Valve Seat		Metal to metal seated valves	
Valve Seat material		316 SS		
SEAL		VTA(soft seal & cover & rod guide)		
MANUFACTURER		VTA		
MODEL no.		VTA		
Ordering code information		VTA		
Certificates & Calibration		pressure test, inspection certificate-Works		
accessary		Marking(Tagging)		

		PROJECT: PP-PE PILOT PLANT		 شرکت ملی صنایع پتروشیمی شرکت پژوهش و فناوری پتروشیمی
		DATA SHEET FOR ON-OFF/PISTON VALVE		
		Contractor Job No:	Doc. No:	
Owner Job No:	Sheet No. :	of		
Pneumatic Piston+Cylinder Actuator	Type of Actuator	Pneumatic Piston+Cylinder		
	Actuator size	VTA		
	Actuator ANGLE (torque)	directly		
	Acting = Spring Return or Double Acting Type	Spring Return (SINGOL ACTION)		
	Air supply press. Barg	6		
	On Air Failure	OPEN		
	Hand wheel + Declutched or Side type	YES (Hand wheel + Declutched)		
	Body material	VTA (lightweight or Aluminium Body)		
	Valve position monitor	YES		
	Air filter regulator + Supply & output pressure gauge	YES		
	MANUFACTURER	VTA		
	MODEL no.	VTA		
	Ordering code information	VTA		
accessary	Marking(Tagging)			
Solenoid	Solenoid Valve Type	3-way solenoid valve		
	Power Supply V DC	24 V DC, power consumption 26.71 mW		
	ENCLOSURE PROTECTION	EE xia , IIC , T6		
	Mounting Position (Remote version or copmact)	Remote version (conection with tube)		
	single actuated with spring return mechanism	YES		
	double actuated with two locking positions	NO		
	On Power Failure	open ways actuator and exhaust and air inside actuator discharges		
	Threaded connection Size	(NPT) 1/2 or (NPT) 1/4		
	Degree of protection	IP 65 with filter check valve		
	Output current (mA)	≥ 1.6 mA		
	Electrical connection	M20 & 1.5		
	MANUFACTURER	VTA		
	Ordering code information	VTA		
accessary	Marking(Tagging)			
Limit Switch Or Proximity Sensor	Type	Quantity	Proximity Sensor - Namur	2 = For close & open
	Power Supply V DC	8 V DC		
	ENCLOSURE PROTECTION	EE xia , IIC , T6		
	Degree of protection	IP 65		
	Electrical connection	M20 & 1.5		
	MANUFACTURER	VTA		
	Ordering code information	VTA		
	accessary	two Safety Barrier		

PROJECT: PP-PE PILOT PLANT

DATA SHEET FOR ON-OFF/PISTON VALVE



شرکت ملی صنایع پتروشیمی
شرکت پژوهش و فناوری پتروشیمی

Contractor Job No:

Doc. No:

Owner Job No:

Sheet No. :

of

PAD 1" 600#

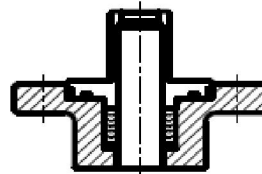
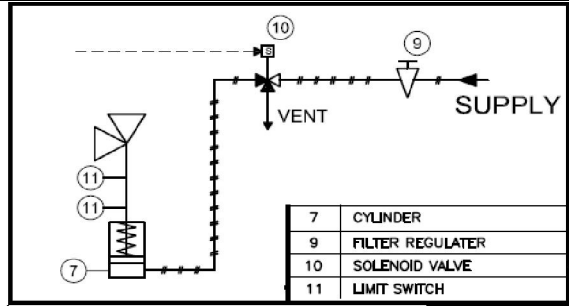
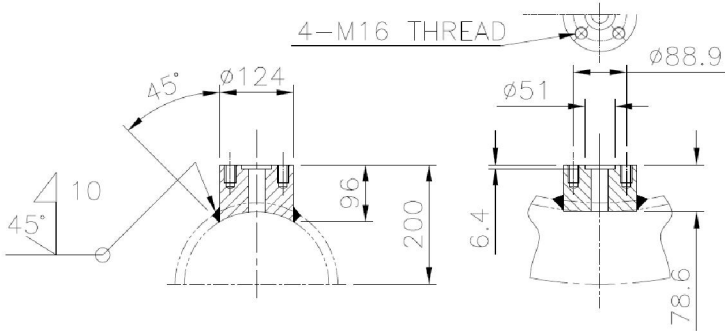

SOFT & METAL SEAL
(With Rod Guide)

Date	Status	Prepared	Checked		Approved

صورت حساب فروش کالا و خدمات

شماره سریال:

تاریخ:

مشخصات فروشنده

نام شخص حقیقی/حقوقی:	شماره اقتصادی:	شماره ثبت / شماره ملی:
نشانی: استان:	کد پستی:	شهر:
نشانی:	شماره تلفن / نامبر:	

مشخصات خریدار

نام شخص حقیقی/حقوقی:	شماره اقتصادی:	شماره ثبت / شماره ملی:
نشانی: استان:	کد پستی:	شهر: تهران
نشانی:	شماره تلفن / نامبر:	

مشخصات کالا یا خدمات مورد معامله

ردیف	شرح کالا یا خدمات	تعداد	مبلغ واحد (ریال)	مبلغ کل (ریال)	مبلغ تخفیف	مبلغ کل پس از تخفیف (ریال)	جمع مالیات و عوارض (ریال)	جمع مبلغ کل بعلاوه جمع مالیات و عوارض (ریال)
۱								
۲								
۳								
۴								
۵								
۶								
۷								
جمع کل								

شرایط و نحوه فروش نقدی غیر نقدی

توضیحات:

مهر و امضاء خریدار

مهر و امضاء فروشنده