

Item	Description	Unit	Quantity			Total
			LLDPE	SAZ	Catalyst PP	
Gland						
1	CABLE GLAND EX SIZE: O20 / Data Sheet No : 1301-1 به همراه شرود و لاگ نت و ارت لاگ	NO	1000	600	200	1800
2	CABLE GLAND EX SIZE: A20 / Data Sheet No : 1301-1 به همراه شرود و لاگ نت و ارت لاگ	NO	1000	600	200	1800
3	CABLE GLAND EX SIZE: M25 / Data Sheet No : 1301-1 به همراه شرود و لاگ نت و ارت لاگ	NO	200	200	50	450
4	CABLE GLAND EX SIZE: M32 / Data Sheet No : 1301-1 به همراه شرود و لاگ نت و ارت لاگ	NO	200	200	50	450

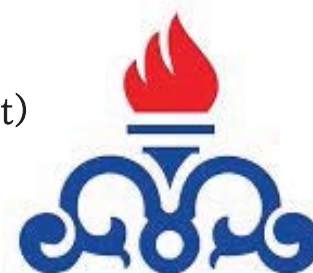

Reference Data Sheet
No : 1301-1

SPECIFICATION

Application	Outdoor and indoor . For use with single wire armour tape and braid armor , elastomer or plastic insulated cables.
Specification	In accordance with the relevant requirements of BS 6121 type E1WF and BS 5501 parts 1,5, EN 50014, EN 50018, IEC 60079-0, IEC 60079-1
Approval	Suitable for use in Group IIA, IIB, and IIC Suitable for use in Zone 1, and Zone 2.
Function	I) provides for armour clamp. II) provides seal on outer sheath of cable III) provides seal on inner sheath of cable
Seals	The inner seal complies with the pressure test of 30 BAR (450 psi) for two minutes.
Marking/certificate No.	Exd IIC IP66/BAS Ex98D 1229U
Ingress protection	IP 66 to IEC 60529
Material	Brass/ Stainless steel
Finish	This gland can be coated or plated to suit the application.
Accessories	Shroud for additional protection against onerous weather conditions.
(Optional)	(Sealing Washer for IP66 rating between gland and the equipment.)
	Earth Tag to ensure earth continuity between the gland and the equipment.
	Locknut to secure the gland body to the equipment where entry hole is not tapped.

Gland Size ref.	'M' Entry thread sizes				'U' Thread Length				P	** Across flats	** Across corners	Cable acceptance details						
	Metric	Imp* (in)	PG	BSPP* BSPT* NPT* (in)	Metric Imp PG	BSPP	BSPT	NPT				Diameter of Inner sheath		Diameter of outer sheath		Standard Steel wire armour R		
												N Min.	N Max.	O Min.	O Max.	SWA	Tape Armor	
Os	16/20	3/4	13.5	1/2	15	15	18.6	19.9	58.7	25	27.7	3.0	7.6	10.5	16.0	0.9 to 1.25	0 to 1	
O	16/20	3/4	11/13.5	1/2	15	15	18.6	19.9	58.7	25	27.7	7.5	11.5	10.5	16.0	0.9 to 1.25	0 to 1	
A	20	3/4	11/16	1/2	15	15	18.6 20	19.9 20.2	57.8	30	34.6	11.3	13.5	12.9	20.5	0.9 to 1.25	0 to 1	
B	25	1	21	3/4	15	15	18.6 20	19.9 20.2	62.5	36	41.6	13.3	19.2	17.0	26.5	1.25 to 1.6	0 to 1	
C	32	1 1/4	29	1 1 1/4	15	15	20 20	23.7 26	65.9	46	53.1	19.3	26.2	25.0	33.3	1.6 to 2	0 to 1	
C2	40	1 1/2	36	1 1/4 1 1/2	15	15	20 20	26 26	73.8	55	63.5	25.5	31.5	33.0	42.0	1.6 to 2	0 to 1	
D	50	2	42/48	2	15	15	20	30.3	26.9	82.3	65	75.1	32.0	43.5	39.5	52.0	2 to 2.5	0 to 1
E	63	2 1/2	-	2 1/2	15	15	20	33.6	39.9	83.1	80	92.4	43.0	54.5	52.0	64.8	2.5	0 to 1

Notes:

* The dimension of cable may vary with manufacturing tolerances. We do advise the actual cable diameter is measured where possible before purchasing Cable Glands.

The recommendations here are given in good faith but SHOMAL can not be held liable for mistakes in selection however caused.

**This dimension is the minimum acceptable.



Reference Data Sheet
No : 1301-1

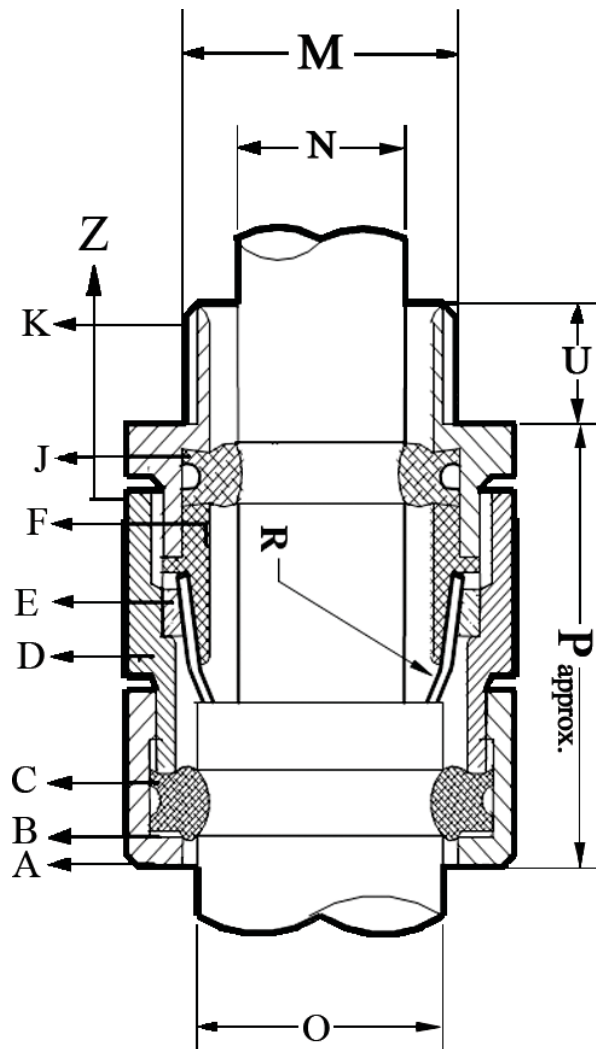

- A : TAIL NUT
- B : SKID WASHER
- C : OUTER SEAL
- D : COMPRESSION NUT
- E : ARMOUR CLAMP RING
- F : ARMOUR CLAMP

Note : Alternative clamping device (EOF) is available for tape Armor and braided cables

- J : INNER SEAL
- K : ENTRY ADAPTOR

Item	Description	Unit	Quantity			Total
			LLDPE	SAZ	Catalyst PP	
JUNCTION BOX						
1	EX JUNCTION BOX MARK V / Data Sheet No : 1801-1 کد رنگ RAL 7032 شامل ریل ترمینال ، قابلیت نصب 10 عدد گلند آرمور سایز M20 در هر طرف (چپ و راست) و قابلیت نصب یک عدد گلند آرمور سایز M32 در قسمت پائین و دارا بودن پیچ اتصال ارت	NO	60	30	20	110
2	Ex Junction box 260*160*91 mm Data Sheet No : 1801-2	NO	20	10	10	40
3	Ex Junction box 160*160*91 mm Data Sheet No : 1801-3	NO	20	10	10	40
4	EX JUNCTION BOX Data Sheet No : 1801-4	NO	40	10	20	70

National Petrochemical Company

Petrochemical Research and Technology Co. (Arak Sit)



Reference Data Sheet

No : 1801-1

SPECIFICATION	
TYPE	MARK V
Application	As terminal or marshaling enclosure
Protection	Ex e II T6/T5 Gb- Ex ia IIC T6/T5 Gb - Ex t IIIC T80°C/T 95°C Db
Marking(ATEX)	Ⓔ II 2 GD
Certificate No.	TÜV 11 ATEX 7155X - IECEx TUR 11.0021X
Standards	IEC60079-0 ,IEC60079-7 , IEC60079-11 , IEC60079-31
Material	A) Stainless steel B) Mild steel
Finish	A) Stainless steel may be coated or painted to suit customer application. B) Mild steel to be coated or painted by the manufacturer or the customer.
Ingress Protection	IP 66,67,68 to IEC 60529
Temperature Class	T6 and T5
Ambient temperature	-40°C to +65°C
Lid Fixing	4 x M8 stainless steel screws.
Earthing	M8 Internal / External stainless steel Earth Stud.
Enclosure Mounting	4 slotted Fixing Brackets for M10 screws.
DRAIN PLUG	As an option

SIDE CABLE ENTRY SELECTION									
THREAD SIZE	M20(O)	M20(A)	M25(B)	M32(C)	M40(C2)	M50(D)	M63(E)	M75(F)	
ACROSS FLATS	25	30	36	46	55	65	80	95	
ACROSS CORNERS	27.7	34.6	41.6	53.1	63.5	75.1	92.4	109.6	
MAX.NO. OF ENTRIES	L	25	15	11	7	4	3	2	-
	R	25	15	11	7	4	3	2	-
	T	17	11	8	4	3	2	2	-
	B	17	11	8	4	3	2	2	-

Dimensions (mm)		
	INTERNAL	EXTERNAL
LENGTH	342±5	417±5
WIDTH	242±5	305±5
HEIGHT	118.5±5	154±5
FIXING BRACKETS	-	385x160±1

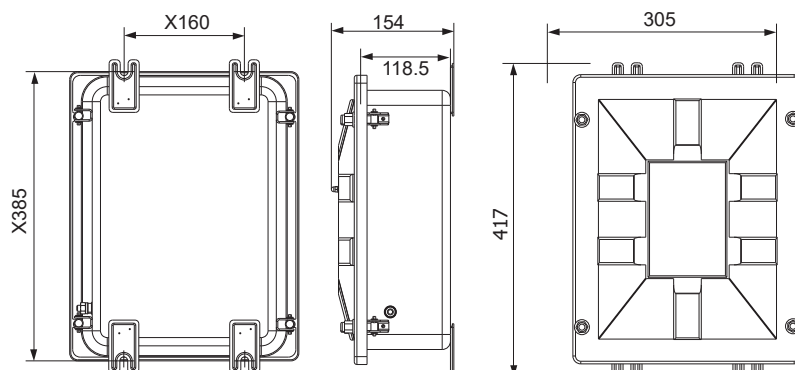

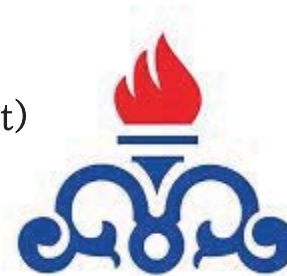

Reference Data Sheet
No: 1801.2

Technical data

Dimensions and weights

Depth	91 mm	Depth (inches)	3.583 inch
Height	160 mm	Height (inches)	6.299 inch
Width	260 mm	Width (inches)	10.236 inch
Mounting dimension - height	110 mm	Mounting dimension - width	240 mm
Net weight	2,091 g		

Temperatures

Operating temperature	-40 °C...80 °C
-----------------------	----------------

Environmental Product Compliance

REACH SVHC	Lead 7439-92-1
------------	----------------

Cable glands, left

M12	8	M16	6
M20	3	M25	2
M32	1	M40	1

Cable glands, right

M12	8	M16	6
M20	3	M25	2
M32	1	M40	1

Cable glands, top/bottom

M12	27	M16	23
M20	13	M25	8
M32	4	M40	3

Certificate numbers enclosure

Approval conditions	cULus, RMRS, DNV	Certificate No. (DNVGL)	TAE00002SM
Certificate No. (EAC)	C-DE.HB07.B.00089-20	Certificate No. (GERMLLOYD)	TAE00002SM
Certificate No. (MARITREG)	19.00108.272	Certificate no. (cULus)	E197061
Certificate no. Terminal Box (EAC)	C-DE.AД54.B.00251/19 Ind. Terminal Box	Certificate no., empty enclosure (EAC)	C-DE.HB07.B.00089/20
Declaration of Conformity No. (DoC LVD)	DE_PS2410_160412_001ISS01		

- (Available in two surface finishes: natural and powder-coated (RAL 7001) •
- (With chloroprene moulded seal as standard (silicone moulded seal optionally available) •
- Standardised closure system with Torx slotted screw head for 19 enclosure sizes •
- Mounting holes outside of the gasket area •
- High IP protection classes: IP66, IP67 and IP68 •

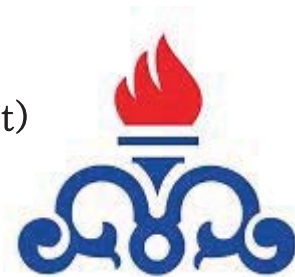

Reference Data Sheet

No: 1801.2

Technical data
General information

Access opening: height	151 mm	Access opening: width	251 mm
Areas of use	Process industry, Transportation, Marine engineering, Packaging industry, Harbour facilities, Machine construction	Enclosure attachment	Holes 6 mm
Flange plate	No	Impact resistance	10 J version standard
Integral fixing	Threaded holes M5	Lid	Yes
Lid attachment	M6 torx stainless steel screws with slot	Material	Aluminium AISi12
Material thickness of cover	4 mm	Material thickness of enclosure	4.5 mm
Note: protection class	IP68 (t=72h, h=1m)	Number of lid screws	4
Operating temperature, max.	80 °C	Operating temperature, min.	-40 °C
Protection class (UL)	Type 4, Type 4x	Protection degree	IP66, IP67, IP68
Seal material	Chloroprene	Standards	EN 45545-2:2013
Surface finish	untreated	Torque for lid screws	2.5 Nm

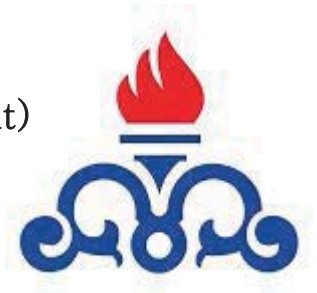

Reference Data Sheet

No: 1801.3

Technical data**Dimensions and weights**

Depth	91 mm	Depth (inches)	3.583 inch
Height	160 mm	Height (inches)	6.299 inch
Width	160 mm	Width (inches)	6.299 inch
Mounting dimension - height	110 mm	Mounting dimension - width	140 mm
Net weight	1,616 g		

Temperatures

Operating temperature -60 °C...135 °C

Environmental Product Compliance

REACH SVHC Lead 7439-92-1

Cable glands, left

M12	8	M16	5
M20	3	M25	2
M32	1		

Cable glands, right

M12	8	M16	5
M20	3	M25	2
M32	1		

Cable glands, top/bottom

M12	14	M16	8
M20	5	M25	3
M32	2	M40	1

Certificate numbers enclosure

Approval conditions	cULus, RMRS, DNV	Certificate No. (DNVGL)	TAE00002SM
Certificate No. (EAC)	C-DE.HB07.B.00089-20	Certificate No. (GERMLLOYD)	TAE00002SM
Certificate No. (MARITREG)	19.00108.272	Certificate no. (cULus)	E197061
Certificate no. Terminal Box (EAC)	C-DE.AД54.B.00251/19 Ind. Terminal Box	Certificate no., empty enclosure (EAC)	C-DE.HB07.B.00089/20
Declaration of Conformity No. (DoC LVD)	DE_PS2410_160412_001ISS01		

- (Available in two surface finishes: natural and powder-coated (RAL 7001) •
- (With chloroprene moulded seal as standard (silicone moulded seal optionally available) •
- Standardised closure system with Torx slotted screw head for 19 enclosure sizes •
- Mounting holes outside of the gasket area •
- High IP protection classes: IP66, IP67 and IP68 •

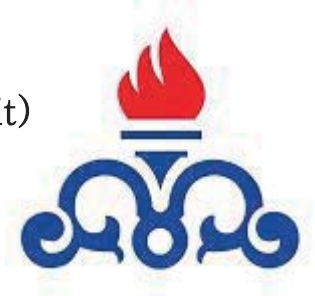

Reference Data Sheet
No: 1801.3

Technical data

General information

Access opening: height	151 mm	Access opening: width	151 mm
Areas of use	Process industry, Transportation, Marine engineering, Packaging industry, Harbour facilities, Machine construction	Enclosure attachment	Holes 6 mm
Flange plate	No	Impact resistance	10 J version standard
Integral fixing	Threaded holes M5	Lid	Yes
Lid attachment	M6 torx stainless steel screws with slot	Material	Aluminium AISi12
Material thickness of cover	4 mm	Material thickness of enclosure	4.5 mm
Note: protection class	IP68 (t=72h, h=1m)	Number of lid screws	4
Operating temperature, max.	135 °C	Operating temperature, min.	-60 °C
Protection class (UL)	Type 4, Type 4x	Protection degree	IP66, IP67, IP68
Seal material	Silicone	Standards	EN 45545-2:2013
Surface finish	Powder-coated, textured	Torque for lid screws	2.5 Nm

vertical assembly

WDU 2,5 / ZDU 2,5 / IDU 2,5	*	WDU 4 / ZDU 4	*
-----------------------------	---	---------------	---

Classifications

ETIM 6.0	EC000261	ETIM 7.0	EC000261
ETIM 8.0	EC000261	ECLASS 9.0	27-18-01-01
ECLASS 9.1	27-18-92-90	ECLASS 10.0	27-18-01-01
ECLASS 11.0	27-18-01-01	ECLASS 12.0	27-18-01-01

National Petrochemical Company

Petrochemical Research and Technology Co. (Arak Sit)

Reference Data Sheet

No : 1801-4



SPECIFICATION	
TYPE	LJB 1
Marking acc to 94/9/EC directive	Ⓔ II 2 GD
EC type examination certificate	TÜV 11 ATEX 7152 X
Marking acc.to IEC	Exd IIC T6 Gb,Ex t IIIC T85°C Db
IEC certificate of conformity	IECEX TUR 11.0019X
Ingress protection to IEC 60529	IP 66 / 67
Permissible ambient temperature	-20°C to +40°C and -30°C to +55°C,(See Table1)
Material	Copper free Aluminum

TABLE 1 Maximum Permitted dissipation power

Tamb (-20°C to +40°C)			Tamb (-30°C to +55°C)			Type of Enclosure
T4 T 135°C	T5 T 100°C	T6 T 85°C	T4 T 135°C	T5 T 100°C	T6 T 85°C	
47 W	26 W	18 W	39 W	18W	10W	LJB 1

TABLE 2 TYPE CONFIGURATION

TYPE	STYLE	Entry From Side
------	-------	-----------------

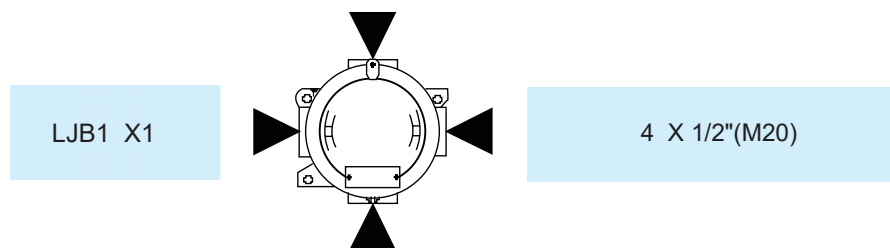

* Other thread forms are available on request.ie.Metric,PG,NPT...

**Other configurations are available on request.Max.number of entries=4

Table 3 :

APPLICATIONS					
Max. Number of terminals	Size	V _{Max}	I _{Max}	Max rail Length	Type of enclosure
10	2.5 mm ²	<750 V	<20A	45 mm	LJB
7	4 mm ²		< 32A		
4 *	6 mm ²		< 40A		

*pillar or column terminals



PAGE \ REV.	0	1	2	3	4	5	PAGE \ REV.	0	1	2	3	4	5	PAGE \ REV.	0	1	2	3	4	5
A	X																			
1	X																			
2	X																			
3	X																			
4	X																			
5	X																			
6	X																			
7	X																			
8	X																			
9	X																			
10	X																			
11	X																			
12	X																			
13	X																			
14	X																			
15	X																			
16	X																			

5							
4							
3							
2							
1							
0	20-Oct-20	M.Asgari	M.Nazeri Nasab	M.Danehgar	M.Asadi	N.Nouhjah	IFA
Rev	Date	Prepared By	Checked By	Approved By	Approved By	Approved By	Status
		Discipline			PEM	PM	

Document Revisions



CONTENTS

1. Purpose
2. Definition
3. Content
4. Instructions concerning vendor's data books presentation
 - 4.1 Language / units
 - 4.2 Size of documents
 - 4.3 Class of documents
 - 4.4 Books form
 - 4.5 Identification
 - 4.6 Internal presentation
 - 4.7 Vendor documents numbering
5. Number of vendor's data books per purchase order
6. Delivery time
7. Transmittal of documentation
8. Documents for engineering
 - 8.1 Vendor drawing and documentation list
 - 8.2 Plate arrangement drawing and material list
 - 8.3 General arrangements drawing
 - 8.4 Detail drawings
 - 8.5 Calculation notes
 - 8.6 Spare parts list
9. Description of inspection and / or acceptance documents
 - 9.1 Material certificates
 - 9.2 Welders qualification
 - 9.3 Hydraulic test report
10. Issuance schedule



National Petrochemical Company
Petrochemical Research & Technology Co.

PP-PE Pilot Plant



شرکت ملی صنایع پتروشیمی
شرکت پژوهش و فناوری پتروشیمی

Title: INSTRUCTION FOR VENDOR DOCUMENTATION

Page: 2

1. Purpose

The purpose of this procedure is to give instructions for preparation of Vendor's data book (mechanical catalogue) applicable to the contract.

2. Definition

VENDOR Companies Awarded by Owner for Procurement Services, Inspection Affairs or Transportation, Providing of Project's goods, following up all transport activities from VENDOR workshop to final destination as defined in the purchase order.

OWNER: Petrochemical Research & Technology Company

3. Content

The Vendor's Data Book shall contain comprehensive detailed information covering design and engineering, inspection and testing, installation, operation and maintenance manual of the equipment and accessories included in, and supplied for the plant.

In addition, VENDOR shall submit the drawings and documents according to the "LIST OF DOCUMENTS REQUIRED FROM VENDOR" given in the requisition / purchase order.

For a sample of the contents of VENDOR's data book refer to Attachment No. 1.

4. **Instructions Concerning Vendor's Data Books Presentation**

4.1 **Language / Units**

All documents and drawings for design and fabrication shall be written in English as well as all Maintenance and Operating Instructions.

All units and dimensions shall be in the metric system except for the following:

- Size of pipe and valve (Inch)
- Flange rating (Pound)

If necessary, other units and dimensions shall be used with OWNER approval.



4.2 Size Of Documents

- All drawings shall be prepared on ISO standard size sheets, i.e.
 - A0 : 840 x 1188 mm
 - A1 : 594 x 840 mm
 - A2 : 420 x 594 mm
 - A3 : 297 x 420 mm
 - A4 : 210 x 297 mm
- Size A0 should be used only with OWNER approval. Larger sizes are not allowed.
- In general all drawings shall be reduced to 297 mm x random length size for convenience in handling.
- All documents other than drawings shall be prepared on standard A3 or A4 size sheets suitable for insertion in an A4 hard-core binder.
- All reduced drawings, data, etc. shall be legible.

4.3 Class Of Documents

All drawings / data submitted must be of good quality that will allow production of legible copies.

- Documents submitted to OWNER for comments:
These documents give all data necessary to understand operation and to appraise the construction method, assembly, disassembly, fastening and connections of equipment. They clearly indicate the scope of supply and specify all details necessary for installation.
- Final documents:
These documents are certified, "As built" documents finally reviewed without comment by OWNER.
OWNER comments on VENDOR documentation shall in no way relieve the VENDOR of his responsibility especially concerning the design of the equipment or facilities.

4.4 Books Form

All the documentation shall be inserted in A4 (297 mm x 210 mm) white color binder (Punch holes shall be two).

Other types, such as folders or boxes with loose sheets, are not acceptable. The thickness of each volume shall under no circumstance exceed that of a normal file (7 cm). The paper level inside each file shall be at least 5 mm below the opening point of the binder.



Drawings and documents with sizes larger than A3 will be folded in plastic jackets inserted in the file, with opening upward.

4.5 Identification

Each Vendor's data book shall be identified on its back and on the cover by a standard label, the format of which is given in Attachment No.2.

4.6 Internal Presentation

All drawings and documents shall be written in English.
Cardboard division sheets shall separate different groups of documents, sheets and directions. At least rigid index sheets with numbering shall separate the different chapters.

The wording and presentation of the reports will be controlled with utmost care.

Consequently, any loose presentation, which may give the OWNER impression of careless work, will be rejected. This applies in particular to:

- All manuscripts or type texts with handwritten comments (except for technical documents on OWNER or Vendor's standard forms).
- All texts in any language other than English, unless they are transmitted together with a translation in compliance with the above requirement.
- All copies that might be questionable: writing too light, dark background areas, dark edge due to poor centering, titled copy, perforation marks, etc.

4.7. Vendor Document Numbering

In addition to the Vendor's document number, VENDOR shall add OWNER's document number.

The block shown here below will be placed on each "first page" of specification, data sheet and each drawing in addition to the Vendor's label.

 National Petrochemical Company / Petrochemical Research & Technology Company PP-PE Pilot Plant				
NPC-RT PP-PE Pilot Plant	Owner Project No.	Rev.	Date	Signature
	Owner Doc/Dwg. No.			
	Sh. Of			



National Petrochemical Company
Petrochemical Research & Technology Co.

PP-PE Pilot Plant



شرکت ملی صنایع پتروشیمی
شرکت پژوهش و فناوری پتروشیمی

Title: INSTRUCTION FOR VENDOR DOCUMENTATION

Page: 5

All other pages of the specifications and data sheets shall have the following block.

Project No.	Owner Project No.	Rev. Sh. Of
OWNER DOC. No.		

5. Number Of Vendor's Data Books Per Purchase Order

If the purchase order includes several separate requisitions or covers several items, which are to be shipped with different vessels, the VENDOR shall supply as many separate Vendor's data books, as there are separate requisitions and/or shipments.

If the requisition covers a large number of items, a common part and specific chapters by item may be planned in agreement with OWNER.

VENDOR shall prepare:

- 3 Copies of the complete VENDOR Data Book.
- Copy of electronic file in CD
- 2 Reproducible copy of final drawings / documents

6. Delivery Time

Documents submitted for review are forwarded in compliance with the dates specified on the Attachment # 2 of requisition.

Final documents shall be forwarded 15 days after receipt of documents commented by OWNER.

Delivery dates are mandatory and a payment installment may be conditioned by the receipt of documents and/or drawings (refer to the order provisions).

7. Transmittal Of Documentation

All drawings and documents shall be transmitted with a transmittal note to the address indicated in the Purchase contract. Purchase order number should be clearly indicated.

Any drawing, which is unreadable, will be returned without fail to the VENDOR who shall in no case use this as an excuse for delivery delay.

Any revision made on documentation should be highlighted with a cloud mark.



8. Documents For Engineering

This paragraph is to clarify OWNER requirements concerning the presentation of some essential engineering documents and drawings submitted for approval. The items indicated below refer to the items listed in the “LIST OF DOCUMENTS REQUIRED FROM THE VENDOR” shown in the attachment # 2 of requisition.

8.1 Vendor Drawing And Documentation List

The VENDOR'S shall provide an exhaustive list of the documentation to be delivered. It should be sent together with the first issue of documents.

8.2 Plate Arrangement Drawing And Material List

This drawing shall be in proper scale.

The plate arrangement drawing or sketch shall indicated as a minimum:

- A general outline of the equipment (shells, heads, supports, skirt, lugs, saddles, stiffeners,etc.) ;
- For columns, shell / cone / skirt development including all internal & external attachments;
- Position of circumferential and longitudinal weld seams in accordance with plates sizes;
- Head shape (and plate arrangement in case of composed head);
- Shape of reduction cone (straight flange, knuckle radius, etc.) ;
- Plate thickness after plate forming;
- Material specification;
- Material list

Approval of this document enables order of main materials to be finalized.

The material list for nozzles shall be presented in schedule form. It shall be established from the nozzles list shown on the engineering arrangement drawing or process data sheet, and shall include:

- Identification (or item), quantity and diameter of nozzles;
- Type, rating, facing and material of flanges;
- Schedule or thickness of nozzle necks;
- Diameter, thickness and material of reinforcements;
- Material, thickness, rating of blind flanges (if any);
- Diameter, quantity, length, thread type, material of stud bolts and nuts;
- Definition, rating, materials of gaskets



This document is prepared from information known when equipment is ordered. Its approval will allow the above accessories to be supplied.

Any modifications of one of the items listed above will involve revision of the documents and be followed by new approval.

After approval, the material list shall be transferred on the VENDOR general arrangement drawing.

Note: these documents do not apply to storage tanks.

8.3 Item: General Arrangement Drawing

The VENDOR can start fabrication only after receiving OWNER approval of this document as a minimum.

This drawing shall be in proper scale.

This drawing shall give the following technical information:

- Main dimensions, overall length, minimum thickness of major components;
- Design code, design pressure and temperature, hydrostatic test pressure, non-destructive tests, heat treatment, etc.;
- Corresponding material specification;
- Location and orientation of weld seams (shells, heads, skirt, etc.);
- Shape of heads or, type/ angle of roof for storage tanks;
- Location, orientation of nozzle gussets and other external welded Attachments;
- Location & orientation of internals (trays supports, coils, demisters, baffles, etc.);
- List of nozzles and connections in accordance with material list (dia., type, rating, schedule, etc.);
- Gaskets and bolting (type, material, etc.);
- All information of scope of supply;
- All information on anchoring system;
- Fabricated weight;
- Empty weight;
- Hydro test weight;
- Operating weight;
- Net weight of removable parts;
- Type of paint and its surface preparation;
- North direction;
- List of detail drawings;
- Insulation / fire proofing support detail;

Note: OWNER guide drawings shall not be used as construction drawings.



8.4 Detail Drawings

These drawings shall include references to general arrangement drawing and show:

- Detail of all accessories, internal and external attachment (gussets, etc.): With weld geometry and specification in accordance with approved welding procedure;
- Weight and dimension of removable internals;
- Part list of the various elements;
- Weld geometry and specification in accordance with approved welding procedure;
- All information required on manufacturer name plate;
- Insulation / Fire proofing support detail;
- All construction details not covered above;

All this information may be shown on general arrangement drawing, at Vendor's choice.

8.5 Calculation Notes

Calculation notes shall be in accordance with general arrangement drawing. VENDOR shall establish calculation notes for each equipment. They shall in all cases be included in "manufacturer file".

These documents shall be clearly marked with identification numbers as other VENDOR documents.

They shall include full reference to information sources (codes, formulas, etc.) used for design.

These documents shall be transmitted for review / approval to OWNER. These documents shall be approved prior to general arrangement drawing approval. OWNER approval shall in no case relieve the VENDOR from his responsibilities.

8.6 Spare Parts List

SPARE PARTS LIST AND INTERCHANGEABILITY RECORD (SPIR form) to be filled out by VENDOR according to its filling procedure.

9. Description Of Inspection And/Or Acceptance Documents

This paragraph clarifies OWNER requirements for documents relating to inspection and acceptance of equipment.

The items indicated below refer to the items listed in the "LIST OF DOCUMENTS REQUIRED FROM THE VENDOR" included in the requisition.



9.1 Material Certificates

All pressurized parts shall be considered as main components requiring certificates type 3

.1. B including:

- Shell, heads, cones
- Skirt, saddles, support brackets
- Tubes, flanges, forging, internal piping, nozzle necks
- Bolting for nozzle and shell flanges
- Welding material

9.2 Welders Qualification

This document shall contain all the information concerning:

- Welders (name, number, mark)
- Welding procedure
- Base material (specification, thickness, etc.)
- Welding material (specification, diameter, etc.)
- Electrode type
- Destructive tests results (bending, tensile, impact tests)

All information required on the QW 484 forms given by ASME section IX shall be considered as a minimum.

9.3 Hydraulic Test Report

This document shall contain the following information:

- Type and volume of equipment
- Contained gas analysis
- Description of equipment (length, width or diameter, nature of base material, thickness)
- Construction number and date
- Hydrostatic test pressure in letters
- Date of inspection (before test) and inspector's name
- Hydrostatic test data
- Signatures of inspectors

10. Issuance Schedule

Final Vendor's data books should normally be shipped to the OWNER as per agreed delivery schedule specified in PO of the relevant equipment.

Such final Vendor's data books shall be an integral part of the Vendor's services set forth in the purchase order and the following precautions must be taken in order to meet the above shipping requirements:



National Petrochemical Company
Petrochemical Research & Technology Co.

PP-PE Pilot Plant



شرکت ملی صنایع پتروشیمی
شرکت پژوهش و فناوری پتروشیمی

Title: INSTRUCTION FOR VENDOR DOCUMENTATION

Page: 10

At the latest 2 months before the scheduled delivery date, the VENDOR shall transmit the Vendor's data book model to OWNER for comments and approval.

The model shall be in conformity with the final internal and external presentation and shall contain all documents required for the final report.

A non- completed form will replace the final acceptance documents, which do not exist at that stage.

Note: Recommendation for handling, transport and storage shall be shipped in box together with the equipment.



National Petrochemical Company
Petrochemical Research & Technology Co.

PP-PE Pilot Plant



شرکت ملی صنایع پتروشیمی
شرکت پژوهش و فناوری پتروشیمی

Title: INSTRUCTION FOR VENDOR DOCUMENTATION

Page: 11

ATTACHMENT # 1

VENDOR DATA BOOK'S CONTENT (SAMPLE)



PART 1 : General Descripton Of The Equipment

- 1.1. OWNER's requisition
- 1.2. General description including OWNER's specifications and data sheets and drawings

PART 2 : Recommendations For Storage, Handling And Lifting

- 2.1. Special precautions for handling prior erection (1)
- 2.2. Recommendations for storage prior and during erection

PART 3: Erection

- 3.1. List of components to be erected/installed on site
- 3.2. Detailed schedule of the erection including hypothesis taken into account
- 3.3. Procedures for erection and installation of the equipment
- 3.4. Schedule of connection points detailing locations and dimensions
- 3.5. Electrical terminal wiring diagrams
- 3.6. Details of site assembly, and filed welds
- 3.7. List of special tools for site erection and assembly
- 3.8. Procedures for site assembly, leveling and welding
- 3.9. Welding specifications for field welds
- 3.10. List of checks and tests to be performed on site
- 3.11. Site testing and acceptance procedures
- 3.12. Procedures for preparation of the equipment for commissioning (including the calibration of instruments)
- 3.13. List of works to be implemented on site instead of Vendor's shop (When required)
- 3.14. Weight (empty, full of water)

PART 4 : Start-Up Running Instructions

- 4.1. General
- 4.2. Principle
- 4.3. Operation
- 4.4. Description of the apparatus
- 4.5. Commissioning
- 4.6. Running instructions



PART 5 : Maintenance Instructions

- 5.1. Maintenance
- 5.2. Safety instructions
- 5.3. General maintenance
- 5.4. Lubricant table and equivalence
- 5.5. Trouble shooting check lists and diagrams
- 5.6. Maintenance Schedule

PART 6: Spare Parts (2), (6)

- 6.1. Spare parts for erection, precommissioning, commissioning and start-up
- 6.2. Spare parts for 2 years operation
- 6.3. Sectional drawings

PART 7: Manufacturer's Documents / Drawings (3)

- 7.1. List of drawings (4)
- 7.2. Manufacturer's data report
- 7.3. Drawings (5)
- 7.4. Calculation notes
- 7.5. Curves and technical data (including P.W.H.T. if applicable)
- 7.6. MANUFACTURER name plate photography

PART 8: Quality Assurance And Manufacturing Documents

- 8.1. Material test certificates
- 8.2. Welding Inspection controls and test reports
- 8.3. Welding procedure specification
- 8.4. Welding procedure qualification reports
- 8.5. Welder qualification reports
- 8.6. Weld identification
- 8.7. Plate identification sketch with heat numbers
- 8.8. Certificate of shop inspection (before hydrostatic test)
- 8.9. X-Ray identification
- 8.10. Radiographic procedure qualification
- 8.11. Radiographic reports along with radiographs
- 8.12. Batch test certificates from manufactures for electrodes
- 8.13. Hydrostatic and other test results and reports (such as visual control and N.D.T., etc.).
- 8.14. Precommissioning / commissioning check Lists & procedures
- 8.15. All other requirements as specified in the respective specifications



National Petrochemical Company
Petrochemical Research & Technology Co.

PP-PE Pilot Plant



شرکت ملی صنایع پتروشیمی
شرکت پژوهش و فناوری پتروشیمی

Title: INSTRUCTION FOR VENDOR DOCUMENTATION

Page: 14

Remarks

- (1) Including a copy of transportation drawing
- (2) No spare parts price must be incorporated in this book
- (3) Only issues approved by as “FINAL”
- (4) Only the drawings included in this part 7.
- (5) Drawings larger than A3 format must be folded and inserted in individual plastic skirts.
- (6) Sufficient information to be prepared for spare parts Such as: materials of construction sizes / three proposed Vendor's, etc.



National Petrochemical Company
Petrochemical Research & Technology Co.

PP-PE Pilot Plant



شرکت ملی صنایع پتروشیمی
شرکت پژوهش و فناوری پتروشیمی

Title: INSTRUCTION FOR VENDOR DOCUMENTATION

Page: 15

ATTACHMENT # 2

VENDOR'S DATA BOOK

COVER



Attachment #8 Instruction for making Data CD

• CD Title CASE

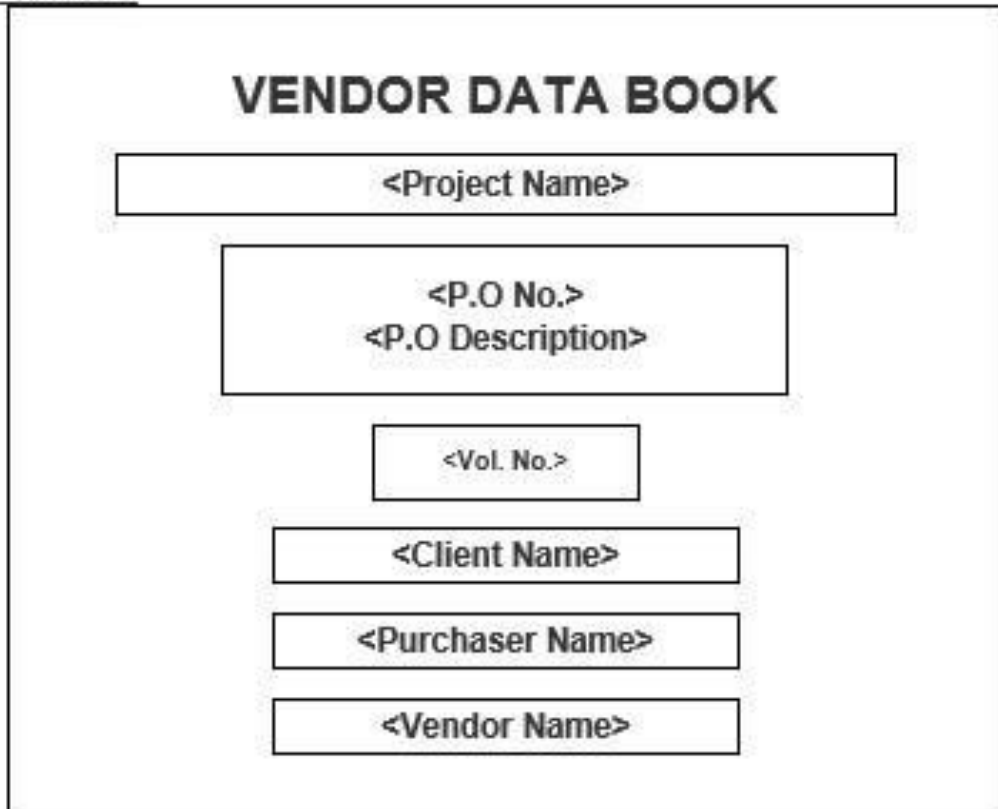

• Construction of the Data Folder

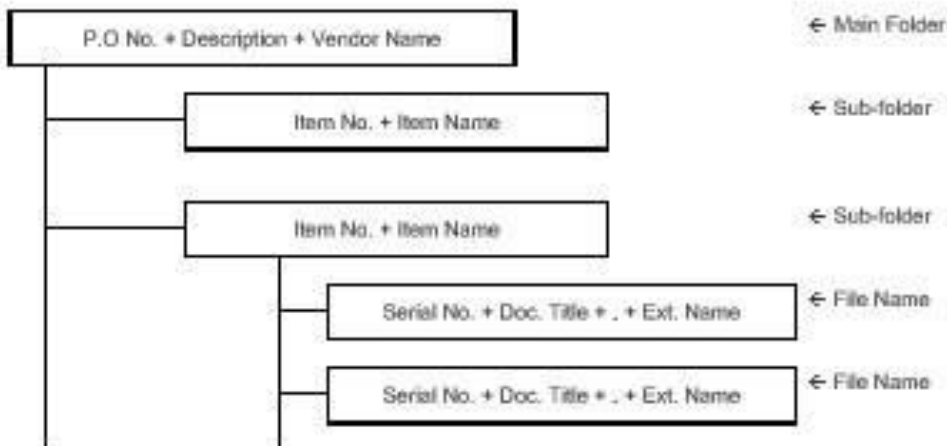



National Petrochemical Company
Petrochemical Research & Technology Co.

PP-PE Pilot Plant



شرکت ملی صنایع پتروشیمی
شرکت پژوهش و فناوری پتروشیمی

Title: PACKING AND MARKING PROCEDURE

Page: A

PAGE	REV.						PAGE	REV.						PAGE	REV.					
	0	1	2	3	4	5		0	1	2	3	4	5		0	1	2	3	4	5
A	X																			
1	X																			
2	X																			
3	X																			
4	X																			
5	X																			
6	X																			
7	X																			
8	X																			
9	X																			
10	X																			

5							
4							
3							
2							
1							
0	20-Oct-20	M.Asgari	M.Nazeri Nasab	M.Daneshgar	M.Asadi	N.Nouhjah	IFA
Rev	Date	Prepared By	Checked By	Approved By	Approved By	Approved By	Status
		Discipline			PEM	PM	

Document Revisions



National Petrochemical Company
Petrochemical Research & Technology Co.

PP-PE Pilot Plant



شرکت ملی صنایع پتروشیمی
شرکت پژوهش و فناوری پتروشیمی

Title: PACKING AND MARKING PROCEDURE

Page: 1

CONTENTS

1. Scope
2. Purpose
3. Definitions
4. Packing for Equipment and Materials
5. Packing and Marking for Electrical Panels And Instruments



1. Scope

- 1.1 This procedure gives the information for Packing and Marking and it is to be applied to vendors for the preparation, protection and packaging of materials, equipment, requiring export shipments for the PP-PE Pilot Plant Project to be built in Petrochemical Research & Technology Company, Arak/Iran.

The following instructions are intended as minimum requirements, and adherence to these instructions in no way, absolves or relieves Vendors of any responsibility or obligation outlined in the Purchase Order.

2 . Purpose

This document defines the criteria required by the Project in relation to the packing and marking of both Project's Equipment and materials including Electrical Panels and Instruments.

3. Definitions

OWNER	Petrochemical Research & Technology Company
PROJECT	PP-PE Pilot Plant
GOODS	All kind of materials and equipment to be incorporated in the Project.
VENDOR	Companies Awarded by Owner for Procurement Services, Inspection Affairs or Transportation, Providing of Project's goods, following up all transport activities from VENDOR workshop to final destination as defined in the purchase order.

4. Packing For Equipment And Materials

- 4.1 Equipment and material shall be exported packed in compliance with General Purchase Conditions and the best established practice for overseas construction jobs in accordance with the following directives. In the event of any divergence between this specification and the established practice, this specification shall govern.
- 4.1.1. "Seaworthy and tropical proof " according to international standard.
- 4.1.2 Packing and conservation of goods shall be sufficient to protect them from damage during transit from point of manufacture to the delivery at job site under conditions



which may involve multiple handling, extended storage, exposure to moisture and the possibility of pilferage. The contents must withstand one year transit conditions without suffering damage and Vendors shall give recommendations for a further two(2) years storage under SITE conditions.

Required storage facilities and procedure shall be advised by manufacturer/seller in advance.

- 4.1.3 The packing of the equipment and materials shall be carried out in order to comply with transport conditions.
- 4.1.4 Individual packages shall be kept as small in bulk as possible.
- 4.1.5 Individual packages exceeding a gross weight of 3,000 kgs shall be avoided, if possible.
- 4.1.6 Kind and dimension of packages shall be chosen to suit overseas transport in containers and to fully utilize the size of containers.
- 4.1.7 The following inside dimension of containers are to be observed :
40-foot-containers : 1195x220x205 cms.
20-foot-containers : 595x220x205 cms.

4.2 Modes of Packing

In accordance with the nature of the contents, the following modes of packing shall be considered:

- a) wooden cases
- b) wooden crates
- c) skid-construction (for vessels etc.)
- d) non-returnable steel drums (export variety)
- e) non-returnable cable reels
- f) bales
- g) 20 ft - 40 ft non-refundable containers

4.3 General Rules for Packing

- 4.3.1 Cases and crates shall be made from new, sound and seasoned lumber. Sheathing shall be of min 24 mm thickness.
If so required for static reasons, thicker sheathing shall be used, in accordance with size and weight of the package. Timber crates and boxes shall be strong enough to withstand without any damage , transport on ship board at sea and numerous handling between the works and the port of origin and between the port of destination and the site.



- 4.3.2 Cases and crates with gross weight up to 1,000 kgs shall be provided with bottom cleats of min. 40 mm thickness to ensure clearance for handling by forklift. Cases and crates exceeding gross weight of 1,000 kgs shall be provided with skid runners, number and size according to weight of package.
- 4.3.3 The contents of cases shall be protected by waterproof and strong plastic foil which shall be sealed by welding. An adequate quantity of moisture absorbent (silica gel) shall be added to protect the contents for sufficiently long time from corrosion.
- 4.3.4 Felt , cellophane paper, polyester cuttings , crepe cellulose and some equally efficient materials may be used for padding or cushioning. Wood shavings and other paper shall not be used for padding or cushioning.
- 4.3.5 Materials shall be protected against corrosion during transit as necessary. All bright and machined parts shall be coated with a recognized rust preventative suited to the particular application concerned. All internal parts of machinery shall be treated with lubricant containing rust and oxidation inhibitors to protect equipment from any damage possible. Such lubricants shall be compatible with those which will subsequently be used in service and shall be identified by appropriate tagging.
- 4.3.6 When required, materials shall be painted or coated in accordance with the particulars contained in the purchase order and/or specifications.
- 4.3.7 All flanges, machined working surfaces and threaded parts of all equipment shall be suitably protected . All flanged connections of vessels shall be protected by metal plates correctly gasketed by wooden plugs or plastic caps suitably secured in position.
- 4.3.8 Units or parts belonging to main equipment but separately packed shall be clearly marked for easy identification with the main equipment to which they relate.
- 4.3.9 Packages containing "FRAGILE" articles shall be appropriately packed and in addition to the words "FRAGILE-HANDLE WITH CARE" being stenciled on two opposite sides, internationally recognized symbols shall also be used "This Side Up".
- 4.3.10 Pipe, structural steel sections and plates shall be strapped in bundles of convenient size and weight for handling. Rolled and shaped plates shall be provided with suitable bracing to eliminate distortion during transit, and shall be bundled in uniform lengths. The weight of each bundle shall be within the breaking strain of the steel wrapping. Each bundle shall be marked with a metal tag ,hard stamped, secured under steel wrapping. A 2000 kg limitation shall be imposed for lifts in this category. Where practicable long lengths shall be limited to 12.2 meters to avoid long length carriers. All small steel sections, handrail stanchions, gusset plates etc. shall be boxed.
- 4.3.11 Black steel pipes with an outside diameter of up to 168.3 mm shall be bundled by strapping cleats above and below the load, with boards between each pipe layer and secured by bolts.



Black steel pipes exceeding the above outside diameter shall be treated as an individual package and marked accordingly.

All black steel pipes shall be protected by means of TECTYL spray. The pipe ends shall be closed with plastic caps.

If, in case of pipes with large diameters, the pipe ends cannot be closed with plastic caps, the interior of the pipes shall also be protected and sprayed with TECTYL.

4.3.12 Bitumen coated pipes shall be prepared, packed and handled according to established practice.

4.3.13 Stainless steel pipes shall be packed in wooden cases.
Protection with TECTYL is not necessary.

4.3.14 All valves and fittings (pipe elbows, flanges, etc.) shall be suitably protected and their method of shipment shall be:

- a) All valves and fittings shall be suitably packed and shipped in metal strapped or wood re-enforced waterproof wooden cases with metal corner protection .
- b) All treaded fittings shall be greased and provided with plastic caps.
- c) Control valves shall be packed in wooden cases having adequately designed interior support with interior water proof protection .

4.3.15 Apparatus and vessels shall, where possible, be packed on skid constructions and secured with adjustable steel straps. All unprotected surfaces shall be sprayed with TECTYL. Manholes and other major openings shall be protected with either plastic caps or wooden lids, which shall be firmly secured. Smaller openings shall be closed with plastic plugs.

4.3.16 All vessel internals and items not installed by the vendor at works including accessories such as small parts, bolts, nuts, gaskets etc. shall be packed in wooden cases separately for each vessel or apparatus and marked with the same item number as the vessel/apparatus in order to protect all parts from loss or damage in transit. Internals, bolts and gaskets for service/ testing operations shall be supplied with the vessels/items by the vendor and all internals, boxed separately and marked according to marking procedures. Each item shall be supplied correctly and identified for field installation by others.

NOTE: It is imperative that all these items be clearly listed on the packing list.

4.3.17 Fire bricks, special tiles and insulation refractories shall be boxed after sealing in a polyethylene liner. These boxes shall be skid mounted. Instructions regarding storage prior to installation shall be stenciled on each box with particular reference to adverse weather/temperature/humidity conditions.

4.3.18 All electrical motors whether coupled or uncoupled, generatorors and electrical equipment shall have all openings sealed with protective tape, shall be packed in suitable weather proof skid mounted boxes, and protected from moisture ingress by desiccant as described above.



Items with brushes shall be brushed and rust removed before shipment.

All electrical equipment shall be suitably protected to withstand 1 year transit conditions and Vendors shall give recommendations for a further , 2 years storage under site conditions

Batteries shall be shipped dry with electrolyte packed separately and shall include charging instructions.

4.3.19 All electronic and pneumatic instruments to be packed in accordance with given instructions and must be suitably protected to withstand 1 year transit conditions and Vendors are to give recommendations for a further 2 years storage under site conditions.

4.3.20 Pipeline / vessel insulation shall be packed in double water-proof wooden plywood cases and secured to pallets.
Drums of insulation mastic will also be shipped on pallets.

4.3.21 Spare parts for two years operation, which shall be individually tagged, must be covered with a suitable preservative and wrapped with greaseproof paper and be packed in separate cases from the base item. The cases are to bear the markings as specified and in addition the words "SPARE PARTS FOR TWO YEARS OPERATION".

4.3.22 Commissioning spares shall be individually tagged and marked "COMMISSIONING SPARES" and shall be packed and shipped with the base item.

4.3.23 All vessels/heat exchangers or items of such kind shall be dried, thoroughly cleaned inside and be free of all dirt and loose materials.

4.3.24 Should any materials be scheduled to be freighted as deck cargo, additional packing instructions may be required; the Vendor will advise, for vessels and columns, which shipment cradles will be used throughout the transportation. Cradles to be secured to vessels and columns, by strapping.

4.3.25 Paper bags suitably boxed, or water tight Steel Drums will be used for shipping cement, special aggregate, etc. Paperbags must not be less substantial than 60 lbs outer wall, 40 lbs inner wall and one moisture craft inner wall.

4.3.26 Unless otherwise specified, all export cases, boxes, bundles and containers are to be securely metal strapped with a minimum of two unannealed steel straps in each of two right angled and opposite directions, or where applicable wood re-enforced.

NOTE: Should consignments arrive at the shipment point of origin visually damaged, the shipping agent will advise and await instruction before onward shippings.

4.3.27 All bulk items, lighting, fittings, cable glands, switches etc. are to be packed in batches sufficient for a specific volume of work.



- 4.3.28 Cases and crates shall, according to their weight and size , be provided with two or more steel straps made of unannealed steel, applied with a stretching tool and secured with crimped steel seals.
- 4.3.29 Fittings (valves, pipe elbows, flanges, etc.) must be packed in wooden cases and must be protected.
- 4.3.30 Accessories for apparatus and vessels (small parts, bolts, nuts, washers, gaskets, etc.) are to be packed in wooden cases, separately for each apparatus or vessel. These cases must be marked with the same item No. as the apparatus/vessel to which it belongs (see also Item 5 - packing lists).
All commissioning spare parts to be packed separately, being the packing marked with the relevant main item.

4.4 Marking of Packages

- 4.4.1 All packages shall be clearly stencilled on two opposite sides with black, indelible and seawater proof paint, as follows:
Wherever possible , the stenciled characters shall be 8 cms high.
In case the surfaces of a package are too small to permit stenciling, sheet metal tags shall be embossed with the above marking and shall be securely fastened on two opposite ends of the package.
- 4.4.2 If necessary, packages shall be additionally marked with cautionary symbols on two opposite ends.
- 4.4.3 Packages which may be stored in the open but under a tarpaulin, shall be marked with a red "double roof" symbol.
- 4.4.4 Packages which are to be stored in closed and dry places shall be marked with a red "double roof" symbol.
- 4.4.5 The system of package-numbering shall be indicated to the OWNER in due course of time.
- 4.4.6 The gross weight shall be determined by the party who is responsible for the packing of the items/materials.
- 4.4.7 Example for marking of packages is shown in attach 1.

4.5 Packing list

The packing lists shall be prepared on standard forms :
The necessary number of forms will be made available to OWNER , who shall advise about the quantity required.
The packing list forms shall be filled in ENGLISH language.



National Petrochemical Company
Petrochemical Research & Technology Co.

PP-PE Pilot Plant



شرکت ملی صنایع پتروشیمی
شرکت پژوهش و فناوری پتروشیمی

Title: PACKING AND MARKING PROCEDURE

Page: 8

OWNER shall supply VENDOR with a specimen packing list showing how it is to be filled in.

At the same time OWNER shall be informed of the package numbers required for marking the packages. one column of the packing list shall be filled in with OWNER "ITEM NO. " These item numbers shall be taken from the order form. Special attention shall be paid to the order form that the item number is correctly attributed to the goods to which it belongs . If any question should arise in this respect VENDOR shall contact the OWNERS Representative.

Special care shall be taken that all accessory parts loose or detachable, belonging to the main item under dispatch, shall also be individually listed in the packing list. In the event these accessory parts are not listed in the packing list , they shall be considered by OWNER as not delivered.

Two copies of the packing list in a water-proof plastic envelope shall securely be mailed under a galvanized steel sheet on the outer surface of the package The final packing list in 2-folds shall be available in OWNERS office 10 (TEN) working days prior to dispatch of the goods from the manufacturer's premises.

4.6 Liability and Guarantee

The party responsible for the packing shall be fully liable for and guarantee proper, sufficient and adequate packing, completeness of the contents, protection of the contents for a storage time of 12 month starting from the date when the equipment is loaded on the ship, and the correct preparation of the packing list.

All cost whatever resulting from inadequate or insufficient packing shall be fully charged to the responsible party.

5. Packing And Marking For Electrical Panels And Instruments

5.1 Scope

This section covers the method for packaging of electric and instrument panels for export delivery, which are to be provided with full protection against physical damage and atmospheric attack during transit and possible long periods under adverse storage conditions which may extend to two years.

5.2 General

This specification is for the package Vendor's guidance only.

Vendor shall remain fully responsible for selecting suitable materials for proper packaging and shall comply with the latest issues of the following European or British Standards: Where standards conflict with this specification, specification shall govern .

- Packing Code
- Silica gel for use as desiccant for packages
- Method of determining the permeability of materials used for packaging.



The Vendor shall provide written instructions for the removal of protective coatings and devices.

5.3 Method

5.3.1 The instrument or panel which shall be thoroughly clean, dry and free from rust shall be totally enclosed in a polythene shroud after sharp projections on the instrument or panel have been padded . Silica gel or other approved desiccant shall be strapped inside the shroud, but shall not come into contact with the paint work.

After the desiccant is strapped into position, the open ends of the shroud shall be heat sealed , only leaving an opening large enough for the insertion of an air extracting pipe. After extraction of the air from the shroud, the opening shall be completely sealed.

5.3.2 Packing Case Materials

- All wood shall be thoroughly seasoned and thoroughly sound without knots, knot holes, shakes and checks .
- Wood which can cause metallic such as oak , western red cedar and sweet chestnut shall not be used .
- The case shall be of sill base type. All sheating shall be tongued and grooved.

5.3.3 Packing Case Lining

The packing case shall be lined with completely multilayer waterproof.

The lining shall have as few joints as possible. If joints are necessary, the pieces shall be overlapped so that any rain water which may penetrate the case is shed automatically when the case is upright. Overlaps shall be 75 mm minimum Joints shall be made with Bostik 'C'.

5.3.4 Securing Instruments or Panels Inside Packing Case.

- a)The instrument or panel shall be completely secured by wooden battens faced with suitable rubber or other shock absorbing materials.
- b)Wood, wool and other hydroscopic shall not be used.
- c)Hay and straw shall not be used.

5.3.5 Sealing of Packing Case

After nailing, joints in the case shall be sealed with Bostik Sealing Compound and the outside bound with steel strapping .

5.4 Marking of Packing Cases

5.4.1 Cases which are for Carriage by sea shall be marked "*HOLD STORAGE*".

5.4.2 All cases shall be marked to indicate the correct way up and bear the marking described here in above.



National Petrochemical Company
Petrochemical Research & Technology Co.

PP-PE Pilot Plant



شرکت ملی صنایع پتروشیمی
شرکت پژوهش و فناوری پتروشیمی

Title: PACKING AND MARKING PROCEDURE

Page: 10

ATTACHMENT No.1

MARKING OF PACKAGES

PROJECT :

PROJECT No. :

L/C No. :

OWNER :

ORDERED BY :

ORDER No. :

FINAL DESTINATION : Pouyesh Site, Arak / Iran

STORAGE CODE :

DIMENSION : L x W x H

GROSS WEIGHT :

NET WEIGHT :

PACKAGE No. : _____ OF _____ .

MADE IN :



National Petrochemical Company
Petrochemical Research & Technology Co.

PP-PE Pilot Plant



شرکت ملی صنایع پتروشیمی
شرکت پژوهش و فناوری پتروشیمی

Title: SPARE PARTS PROCEDURE

Page: A

PAGE	REV.	0	1	2	3	4	5	PAGE	REV.	0	1	2	3	4	5	PAGE	REV.	0	1	2	3	4	5
A	X																						
1	X																						
2	X																						
3	X																						
4	X																						
5	X																						
6	X																						
7	X																						
8	X																						
9	X																						
10	X																						
11	X																						
12	X																						
13	X																						
14	X																						
15	X																						
16	X																						
17	X																						
18	X																						
19	X																						
20	X																						
21	X																						
22	X																						
23	X																						
24	X																						
25	X																						
26	X																						
27	X																						
28	X																						
29	X																						
5																							
4																							
3																							
2																							
1																							
0	20-Oct-20	M.Asgari	M.Nazeri Nasab	M.Daneshgar	M.Asadi	N.Nouhjah	IFA																
Rev	Date	Prepared By	Checked By	Approved By	Approved By	Approved By	Status																
		Discipline			PEM	PM																	

Document Revisions



National Petrochemical Company
Petrochemical Research & Technology Co.

PP-PE Pilot Plant



شرکت ملی صنایع پتروشیمی
شرکت پژوهش و فناوری پتروشیمی

Title: SPARE PARTS PROCEDURE

Page: 1

These instructions outline the requirements for providing original manufacturer's pre-commissioning, commissioning and two years operation spare parts for a PP-PE Pilot Plant to be built in Petrochemical Research & Technology Company, Arak/Iran.

CONTENTS

- 1) General information
- 2) Definitions
- 3) Spare parts required
- 4) Required information
- 5) Identification
- 6) Packing and protection
- 7) Special storage items

Attachments:

1. Erection, precommissioning, commissioning and start-up phase spare parts
2. Two years operation spare parts
3. Guidelines for the compilation of Spare Parts Interchangeability Record (SPIR)
4. SPIR form



1) General Information

These instruction outline the requirements for providing original manufacture's pre-commissioning, commissioning and two years operation spare parts for PP-PE Pilot Plant to be built in Petrochemical Research & Technology Company, Arak/Iran.

The Vendor is obliged to provide with an original equipment manufacturer spare parts data package, containing full and complete spare parts information and prices for each item of equipment supplied.

The Vendor shall recommend those spare parts that are deemed necessary on the basis of Vendor's recommendations and experience.

2) Definitions

- 2.1 "Erection, Precommissioning, Commissioning and start-up spare parts" are those material, equipment or components necessary during the erection, precommissioning, commissioning and start-up activities of the Plant.
- 2.2 "Operating Spare Parts" are spare parts material, equipment or components necessary for the continuous operation of the plant after commissioning completion for a period of two years.
- 2.3 GOODS: All kind of materials and equipment to be incorporated in the Project.
- 2.4 VENDOR: Companies Awarded by Owner for Procurement Services, Inspection Affairs or Transportation, Providing of Project's goods, following up all transport activities from VENDOR workshop to final destination as defined in the purchase order.
- 2.5 OWNER: Petrochemical Research & Technology Company.

3) Spare Parts Required

3.1 Capital spare parts

Capital spare parts are defined in documentation prepared by technical department.

3.2 Erection, precommissioning, commissioning and start-up Spare Parts

Vendor is requested to submit a Spare Parts proposal together with base quotation. Such spare parts shall be packed in separate boxes and shipped together with the main equipment/material purchased in order to be available at the site together with the base order supply.

Minimum required quantities are shown in attachment 1.



3.3 Two years operation spare parts

Vendor is requested to submit a Operation Spare Parts quotation based on his experience together with base quotation

The necessary and sufficient two years spare parts include those parts that are normally required to maintain the plant in a satisfactory working condition for a period of two years of continuous operation after plant start-up.

These Operation Spare Parts shall be packed in separate boxes.

Guidelines for selection of two years spare parts are shown in attachment 2.

4) Required Information

4.1 All information and drawings must be in English language.

4.2 Data sheets, engineering drawings, manufacturer's catalogs and operating and maintenance manuals required to identify the function of and fully describe all parts associated with the equipment

4.3 The interchangeability of spare parts must be completely assured between all units contained on the parent equipment purchase order.

4.4 The Vendor shall guarantee the spare parts in accordance with the requirements requested for the parent equipment.

4.5 The offer must be valid for supply either for total or partial quantities.

4.6 All Spare Parts list shall be filled-in using the attached "Spare Parts Card" according also to the instructions attached herein.

Photocopied or hand-written documents are not acceptable.

Twelve (12) months price validity is required

5) Identification

All spare parts shall be individually identified by one of the following methods:

5.1 A stainless steel label imprinted with lettering approximately 6 mm (1/4) high and secured to the part with S.S. wire.

5.2 Inscribing with an electric spark erosion pencil

5.3 On large items inscribing with non-fading, moisture resistant marking ink, figures/ letters to be at least 25 mm (1) high. Ink shall be Pannier 1001 Yellow Industrial or equal.



- 5.4 Items such as Ball Bearings which in actual storage will remain in their packing may be identified with an adhesive label firmly attached to the outside of the carton.
- 5.5 Alternative methods which are standard industrial practice may be used provided SP's approval has been obtained in writing in advance. Stamping directly into spare parts will not be allowed.
- 5.6 The following shall appear on each spare or spare part label:
Manufacturer's real part number.
Short description (one word will suffice if space is limited).
Tag number of equipment (if applicale).

6) Packing And Protection

- 6.1 Packing protection and marking of the packing container shall be as described in Project Packing and Marking Procedure 000-PCR-PRC-0002. Spare parts shall be packed separately from main equipment and the packing containers shall clearly be marked "erection, pre-commissioning, commissioning, and start-up spare parts" or "two years operating spare parts" as applicale. The following additional comments apply :
- 6.2 Packing cases and other shipping containers must be capable of giving adequate protection to contents for a period of one year after despatch from Vendor work-shop (i.e. cases may after receipt at the Plant Site be stored outside before being unpacked).
- 6.3 Two years operating spares are to be protected and packed in such a manner as to ensure a minimum shelf life of four years in an un-air-conditioned warehouse sited in extremely dusty heavy industrial and coastal area with salt pollution location where the maximum shade temperature may exceed -14 +45 C. and where relative humidity reaches 90%.
- 6.4 Consumables items such as bolts and nuts shall be adequately oiled to prevent corrosion.
- 6.5 Other unpackaged items shall be protected by a rust preservative oil, hard drying type. if the nature of the item permits the removal of the deposited tar oil skin by means of petroleum based solvents or the use of hot dip strippable coating.
- 6.6 Any protection for stainless steel parts shall not contain chlorides or harmful metal salts such as Zinc, Lead, Copper. etc. Also marking paint or ink shall not contain similar harmful components.
- 6.7 Electronic and instrument parts shall be packed in sealed clear plastic bags along with a bagged amount of dessicant.

7) Special Storage Items



National Petrochemical Company
Petrochemical Research & Technology Co.

PP-PE Pilot Plant



شرکت ملی صنایع پتروشیمی
شرکت پژوهش و فناوری پتروشیمی

Title: SPARE PARTS PROCEDURE

Page: 5

- 7.1 Vendor must advise of any spares which cannot be stored under the conditions stated in para. 6.2 and which require special storage conditions
- 7.2 Special Storage Items are to be clearly labelled with storage instructions such as:
STORE IN A COOL DRY PLACE AT C
STORE IN DARK PLACE
KEEP HUMIDITY BELOW %
etc.
- 7.3 Owner must be notified of all such items without delay before order placement since a restricted shelf life may require an amendment to order quantity and an appropriate re-ordering procedure.



ATTACHMENT 1

ERECTION, PRECOMMISSIONING, COMMISSIONING AND START UP SPARE PARTS

1) FURNACES

<u>Gaskets for coil:</u>	50%
-Burner Tiles	100%
-Burner Tips	5%
-Fire eyes	10%
-Gas valves seat	100%
-Solenoid valves	25%

2) EXCHANGERS, REACTORS & DRUMS/TANKS

Gaskets for Girth Flange, M/H& H/H	100%
Stud Bolts and Nuts for the Above	5%(Min. 2 Sets)
<u>Field-Installed Trays:</u>	
-Bolts and Nuts	15% (Min. 2 Sets)
-Washers (Metal and Asb.)	20% (Min. 2 Sets)
-Tray Clamps	10% (Min. 2 Sets)
-Asb. Rope and Tape	25% (Min. 2 Sets)
<u>Field-Installed Internals, Piping and Other Bolted Internals:</u>	
Stud Bolts (Alloy and C.S.)	10% (Min. 2 Sets)
Washers and Nuts	10% (Min. 2 Sets)
<u>Packing:</u>	
-Inert Balls	15%
-Raschig Rings / Slotted Rings	15%
-Gaskets Sets And O-Rings	100%
-Fan for Air Cooler	

3) STEEL STRUCTURE AND PLATFORM

Bridge Crane:

-Bolts & Washers	15%
------------------	-----



-Gashels	10%
-Contactors	5%
-Tension Springs	10%
-Fuse Elements	10%
-Gaskets	10%
-Oil Seals	25%
-Relays	5%
-Collectors	1 set Each Size
-Contact Shoes	1 set Each Size
-Limit Switches	1 set Each Size
-Welding Rod	10%

4) MACHINERY / PACKAGES

Please see the relevant engineering specifications of each equipment for commissioning spares.

Electrical Equipment: See item 9

Instrumentation:

- Control panel	See item 10
- Board instruments	See item 10
- Field Transmitters	See item 10
- Field instruments	See item 10
- Others	0%

5) H.V.A.C.

Bolts, Nuts, Gaslets for Field installation of Pipe/Duct	5%
Rotating Equipment	See item 5
Heat Exchangers	0%
Filter Element	1 Set Each Size/Material
Electrical	See Item 9

Instrumentation:

-Control panel	See Item 10
-Board Instruments	See Item 10
-Field Transmitters	See Item 10



-Field Instruments See Item 10
-Others 5%

6) SPECIAL EQUIPMENT

Heat Exchanger See Item 2
Rotating Equipment See Item 5
Filter Element 1 Set Each Size/Mat'l
Piping 0%
Electrical See Item 9

Instrumentation:

-Control panel See Item 10
-Board Instruments See Item 10
-Field Transmitters See Item 10
-Field Instruments See Item 10
-Others 0%

7) PIPING

Gaskets, all sizes 20%
Stud Bolts less than 1" 15%
Stud Bolts 1" to 1 7/8" 10%
Stud Bolts 2" and over 5%
Welding Rods 10%
Coating and Wrapping 10%

	Carbon Steel	Alloy/SS	Cast Iron
Pipe 2" and below	15%	4%	0%
3" to 6"	10%	2%	5%
8" and over	5%	1%	5%
(*) Valves 2" and below			
screwed and welded	10%	5%	0%
(*) flanged	2%	2%	0%



(*) Valves 3" to 10"	2%	2%	0%
(*) Valves over 10"	0%	0%	0%
(*) Flanges up to 12"	5%	3%	0%
(*) 14" and over	2%	2%	0%
(*) Fittings welded up to 2"	10%	6%	0%
(*) 2 1/2" to 10"	5%	3%	0%
(*) 12" and over	3%	2%	0%
(*) Fittings Screwed up to 2"			
(*) 3" and over	5%	3%	0%
(*) Flanged all sizes	5%	3%	0%
(*) Hub and Spigot 3" to 12"	0%	0%	5%
(*) 4" and over	0%	0%	3%

Note: as indicated with (*), where the percent gives the quantity consisting of a whole number plus a decimal less than 0.5, the decimal portion will be dropped; where the decimal portion is 0.5 and more, the next higher whole number quantity will be selected.

8) ELECTRICAL EQUIPMENT

Switchgear, Motor Control Centers MV/LV:

-Fuse elements	50%
-Bulb for Signal Lamps	50%

Local Control Panels & control stations:

-Fuse elements	50%
-Bulb for Signal Lamps	50%

Electirc Motors:

-Grease Nipples where applicable	10%+power terminal (in J.B.) 2%
Lighting Fixtures	3%
Flag Relay	2%
Time Relay	2%
Terminal Block	2%
Auxiliary Relays	1%
Moving Contacts	15%



Fixed Contacts	15%
Coils for Contactors	10%
Boucholz Relay	one of each type and size
Thermometer	
<u>Local Control Station:</u>	5%
-Ammeter	
-Push button	5%
-Selector Switch	5%
<u>UPS:</u>	
-Fuse	*
-MCB (miniature circuit breaker)	*
-SCR	*
-DIOD	*
-Transistor	*
-Control cards	*
-Signaling lamps	*
-Batteries	*
<u>Battery Charger:</u>	
-Fuse	*
-MCB(miniature circuit breaker)	*
-SCR	*
-DIOD	*
-Transistor	*
-Control cards	*
-Signaling lamps	*
-Batteries	*
Fire Alarm System	*
Telephone System	*
Paging System	*
Radio System	*
Emergency Diesel Generator	*
Sockets (400V, 230V, 24V)	5%



Plugs(400V, 230V,24V)	5%
Portable 110V AC, 50Hz, with transformer	5% each type
Socket and plug (ex-type)	
Hand lamp 24V AC, 50Hz(ex-type)	10 no.

All special tools, equipment and spare parts required for commissioning and start-up shall be provided.

These are the spare parts that VENDORS shall recommend based on experience.

9) INSTRUMENTATION

For control Panel:

- Bulbs For Signal Lamps	50%
- Fuse Elements	50%

Boards instruments:

- Fuse elements	50%
- Chart paper for recorders	3 boxes each type
- Ink for Recorder	7 sets each type
- Pens for Recorders	50%

Field transmitters:

- Gasket	15%
----------	-----

Field instruments:

- Air pressure regulators	5%
- Temperature Indicators	10% each range
- Pressure gauges	10% each range
Solenoid Valves	2% each type(min 1 set)
Selonoid coils	3 coil each type
Valve positioners	2% each type(min 1 set)
Cable – Single Pair	20%
Cable – Multi Pair	15%
Cable Glands	20%
Junction Boxes – Large	1 min.
Pipe and Tube	10%



Fittings all type 15% each size

Valves 20%

Manifold Valves 10% each size

Cable Tray 20%

DCS:

- Bulbs for signal lamps 50%

- Fuse elements 50%

- Printer paper, Chart paper 4 boxes each type

- Printer Ribbon 10 sets each type

- Blank Floppy disks/magnetic tape cartridge 10 pieces

Gas Chromatograph:

-Filter elements 10%

-Calibration gas cylinders 1 cylinder (100 liter) each type

-Standard gas cylinders 1 cylinder (100 liter) each type

-Other gas cylinders 1 cylinder (100 liter) each type

Other Analyzers:

-Filter Elements 10%

-Calibration Gas Cylinders 1 cylinder (100 liter) each type

-Standard gas cylinders 1 cylinder (100 liter) each type

-Other gas cylinders 1 cylinder (100 liter) each type

10) PAINT AND INSULATION

Paint 10%

Insulation material 10%

Insulation Band & Seal 10%

Insulating Cement 10%

Insulation Sheet Metal 15%

Insulation Wire 10%

11) UTILITY EQUIPMENT

Heat Exchanger, Vessel, Tank and Tower See item 2



National Petrochemical Company
Petrochemical Research & Technology Co.

PP-PE Pilot Plant



شرکت ملی صنایع پتروشیمی
شرکت پژوهش و فناوری پتروشیمی

Title: SPARE PARTS PROCEDURE

Page: 13

Rotating Equipment	See item 5
Filter Elements	1 Set Each Size/Mat'l
Piping	0%
Electrical	See item 9
<u>Instrumentation :</u>	
-Control panel	See item 10
-Board Instruments	See item 10
-Field Instruments	See item 10
-Others	0%



National Petrochemical Company
Petrochemical Research & Technology Co.

PP-PE Pilot Plant



شرکت ملی صنایع پتروشیمی
شرکت پژوهش و فناوری پتروشیمی

Title: SPARE PARTS PROCEDURE

Page: 14

ATTACHMENT 2

GUIDELINES FOR SELECTION OF 2 YEARS OPERATION SPARE PARTS

Spare parts for equipment are shown in the following tables:

Table 1 – Spare parts for machinery/packages.

Table 2 – Spare parts for electrical equipment

Table 3 – Spare parts for instruments

Table 4 – Spare parts for pressure vessels and heat exchangers

Table 5 – Spare parts for piping.



National Petrochemical Company
Petrochemical Research & Technology Co.

PP-PE Pilot Plant



شرکت ملی صنایع پتروشیمی
شرکت پژوهش و فناوری پتروشیمی

Title: SPARE PARTS PROCEDURE

Page: 15

TABLE 1

SPARE PARTS FOR MACHINERY / PACKAGES

Note 1: Please see the relevant engineering specifications of each equipment for recommended 2-years spares.

Note 2: Please see tables 2 and 3 of attachment-2 for the electrical and instrument spare parts requirements of machinery / packages for 2 -years.



TABLE 2
MINIMUM SPARE PART FOR ELECTRICAL EQUIPMENT

Item:	Quantities
1) Switchgears:	
MV Fuses	15%
Protecting and Flag Relay	2%
Time Relay	2%
Lamps	10%
Space Heaters	10%
L.V. Fuses	2%
Auxiliary Relays	1%
Moving Contacts	15%
Fixed Contacts	15%
Circuit Breakers(MCCB,MCB)	10%
Contactors	15%
Metering	15%
CT	20%
PT	20%
2)Power Motors Control Center: L.V. Fuses	15%
Time Delayed Relays	8%
Lamps	10%
Space Heaters	10%
Terminal Blocks	7%
Auxiliary relays	To be determined later in conjunction with the equipment vendor
Contactors	
Thermal	
overload Relays	
Isolators for each trip	
Current Setting	11%



	Motor Circuit Brakers						
	Complete Unit for Each					15%	(min 1)
	Type & Size(incoming & bus tie)						
	Moving Contacts	20%					
	Fixed Contacts	20%					
	Metering	15%					
	CT	20%					
	PT	20%					
	Circuit Breaker	one per each type					
3) Transformers :	Bucholz Relays	one each type & size					
	Thermometer	10%					
	Bushing HV/LV	50%					
	Measuring and cintrol devices	20%					
	CT of natural resistor	10%	(of each type)				
4) Power Material:	a) Local Control Stations	5%					
	b) Sockets 400V AC	10%					
	c) Plugs 400V AC	10%					
5) Lighting Materials:	a) Switches	10%					
	b) Fuses	30%					
	c) Sockets(230 V, 24V)	10%					
	d) Plugs(230 V, 24V)	10%					
	e) Lighting Fixtures	10%					
	f) Ballast Lamps	5%					
	g) Lamps	20%					
	h) Portable 110V AC,50Hz with transformer (ex-type)socket and plug	10%					
	i) hand amp 24V AC, 50Hz (ex-type)						
6) Motors:							
No of Machines	1	2	3	4	5	more	
set of Bearing	1	1	1	2	2	40%	
Fan, terminal, blocks, space heater (MV)per type						5%	



7) UPS:

Fuses	30%
MCB(miniator circuit breaker)	15%
SCR	30%
Signaling lamps and protection device	15%
DIOD	10%
Transistor	30%
Control cards	one per each type
Batteries	5%
Isolator switch (make before break)	one per each type

8)Battery charger:

Fuse	30%
MCB	15%
SCR	30%
DIOD	10%
Signaling lamp	15%
Control cards	one per each type
Batteries	5%

9)Telephoned system

*

10) Paging system

*

11) Radio system

*

12) Fire alarm system

*

13) Neutral grounding system

*

14) Bus duct

*

These are the spare parts required for two years operation. Vendor shall recommend the spares based on their experience.

(*The Quantities indicated are only preliminary estimation, so the firm quantities will be specified later in conjunction with recommendations of equipment vendors.

The quantities which shall be ordered by VENDOR shall be approved By OWNER.



TABLE 3
SPARE PARTS FOR INSTRUMENTS

<u>Item</u>	<u>Quantities</u>
Flow Instruments	To be determined
Level Instruments	in conjunction with the equipment Vendor
Temperature Instruments	(based on Vendor's experience on similar type of plant)
Pressure Instruments	
Analyzers	
Control Valves : Valve Bodies	None unless service is corrosive or erosive. For corrosive or erosive services, shall be determined in conjunction with the equipment Vendor.
Valve Plugs	1 of each size/min. 15% or 1
Seat Rings	1 of each size/min. 25% or 1
Actuators	10% (min 1 per type / size)
Valve Stems	1 of each diameter. These vary in length depending on valve size. Purchase the longest of each dia. These can be cut to the correct size.



National Petrochemical Company
Petrochemical Research & Technology Co.

PP-PE Pilot Plant



شرکت ملی صنایع پتروشیمی
شرکت پژوهش و فناوری پتروشیمی

Title: SPARE PARTS PROCEDURE

Page: 20

Stem packings	3 boxes of each size used/min. 20%
Grease	3 boxes of each type used/min. 20%
Diaphragms	1 of each size used min. 20%
Blank Orifice Plates	
Dial Thermometers	
Manual Loading Stations	
Instrument Air Filters (Regulation sets)	
Pressure Gauges	
Pressure Switches	
Plug-in Assemblies for Elect. Instr.	
Plug-in Assemblies for Pneum. Instr.	10%
Seal, Condensate and Vent Pots	(for all)
Solenoid Valves	
Thermocouples	
Thermowells	
Signal Lights	
Pneumatic relay and/or boosh(if any)	
Valve Positioners	10%
I/P Convertes	(for all)



DCS/ESD/PLC (for each system the following items):

- I/O cards 5% for each type (min 1 for each type)
- Main cards one set
- Power supply (AC, if any) one set
- Power supply (DC, if any) one set
- Barriers cards 5% for each type (min 1 for each type)

On-line gaschromatographs:

- Main mother board one set
- Column one per type

TABLE 4
SPARE PARTS FOR
PRESSURE VESSELS & HEAT EXCHANGERS

<u>ITEM</u>	<u>QUANTITIES</u>
1) Heat Exchangers-Shell and Tube (U Type included)	
- Tubes	Straight tubes sufficient to retube the largest bundle of each tube size and material.
- Bolts and nuts	(Special or Alloy) of each exchanger minimum one set.
- Gaskets	200%
2) Pressure Vessels	
- Gaskets	200%
- Bolts and nuts	10% (Special, Alloy or size 2" diam or greater), minimum one set.
3) Air Cooled Exchangers	
- Plugs	Steel 1%; Non-ferrous 2% (min. one number)
- Plug Gaskets	5% (min. one number)
-Cover plate gaskets	10%
-Tube support boxes	10% (min. one number)
4) Number of Air-fin Coolers Using Part.	1 2 3 4 5 6 7 or more
(i) V-Belts-Sheaves (Driven & Driver)	0 0 0 0 0 0 1
- Set of Belts	1 2 3 4 5 6 100%
(ii) Fan Shaft Bearing (Upper & Lower)	1 1 1 2 2 3 50% of No of Air Fins
(iii) Speed Reducers (Gear Box) Shaft	



and pinion

- Bearing Set 1 1 1 2 2 3 50% of No
of Air Fins

- O-Rings, Seals, Lock-washers, Locknuts

(iv) Couplings – Complete Coupling,

-Flanges, Gaskets, Seals 1 1 1 1 1 1 1

(v) Fan Assemblies 1 2 3 4 5 6 100% of No
of Air Fins

-Automatic Pitch Control

-Hub Assembly Parts Guide Bushing,

-Pitch Blocks, O-Rings, Clam Gaskets

(vi) Bolt Assemblies, Fork, Pins 1 2 3 4 5 6 100% of No
of Air Fins

(vii) Flexible Hose, Rotary Union 1 1 1 1 1 1 2

(viii) Automatic or Manual Adjustments:

- Blade Retention Clamps, Pitch, 1 1 1 2 2 2 30% of No
of Air Fins

Change Forks, Puch Rod, Stub,(with pilot tubes),Bearing

Retainer Rings

(ix) Spring Housing Gasket, Diaphragm, 1 1 1 1 2 2 20% of No
Blade Retainer Ring, Thrust of Air Fins
cover Gasket

(x) Hub Assembly with Blades 0 0 0 0 0 0 1 (b)

(*) NOTES

(a) Quantities shown are for each size and type of part

(b) Twenty units or more

(c) The parts listed are the principal parts only. Other parts shall be considered for recommendation in quantities consistent with the above table.



National Petrochemical Company
Petrochemical Research & Technology Co.

PP-PE Pilot Plant



شرکت ملی صنایع پتروشیمی
شرکت پژوهش و فناوری پتروشیمی

Title: SPARE PARTS PROCEDURE

Page: 24

5) Plate type Exchangers

Plat gasket	100%
Flow Plate	10%
Nozzle Gasket	200%
Glue (1 Kg. Pot)	1
Special spanner tool	1 for each size/type



TABLE 5
SPARE PARTS FOR PIPING

<u>Item</u>	<u>Quantities</u>
Valves up to 1 ½"	5% for each size, type and material complete units
Valves from 2" to 6"	2% (minimum 2 pieces) for each size , type and material
Valves above 6" to 10"	1 piece for each size, type and material complete units
Valves above 10"	1 only if installed valves quantity is more than 30
Valves up to 10"	
Gland packing and bonnet gasket	10%
Valves from 2" to 10"	2 for each type , size and material set of changeable inner parts
Valves above 10"	1 for each type, size and material
Set interchangeable inner parts: bonnet gasket and stem packing	
Piping gaskets and bolts set for each size and type	10%



ATTACHMENT 3

GUIDELINES FOR THE COMPILATION OF SPARE PARTS

INTERCHANGEABILITY RECORD (SPIR)

The manufacturer/supplier shall complete the following parts of th SPIR form as per listed sequence and in the English language:

- Line 1: PLANT registration/item number or tag number of equipment/instruments, etc. as stated on requisitions and/or Purchase Orders.
- Line 2: Mode, type or other identification of equipment/instruments, etc. ordered.
- Line 3: Serial number of each equipment/instruments, etc. ordered.
- Line 6: Purchase Order number reference of equipment/instruments, etc.
- Line 6a: Unit of measure, i.e. No., set, pair, kg,roll, etc.
- Line 4: Number of identical equipment, etc. of particular model or type being supplied against Purchase Order number mentioned under line 6.
- Line 8: Parts description of all component parts considered by supplier as being required for maintenance of equipment, etc. listed in lines 1, 2 and 3. However, all items specified in the appropriate equipment list shall be shown separately.
- Col. 9: Drawing number/part number as per supplier's parts list or drawing.
- Col. 10: Part identification number shoeing interchangeability within equipment manufacturer's organization.
- Note: Identical parts, regardless of whether they have the same part number or drawing number, should be shown only once (see also line 5).
- Col.11: Material specification of parts listed in column 8.
- Line 5: Enter in appropriate sqare the nubere of parts (listed in column) fitted in each applicable unit. For groups of identical units, denote quantity per unit below quantity shown in line 4.
- Col. 7: Total number of identical parts listed in colimn 8 for all equipment, etc. For identical units multiply quantity in line 5 by number in same column in line 4 and enter overall total of each line in column 7.



- Col.12: Total spare parts recommended for 2 years operation and commissioning period.
- Col.18: Unit price (up to two decimals) for recommended spare parts of column 12.
- Col.20: Original identification number for all items of third party manufacture (bought-out items) such as : ball/-roller bearings, mechanical seals, couplings, bearing lock nuts, bearing lock washers, V-belts, bolts/nuts, gaskets, O-rings, and the like. These items should be fully identified by manufacturers' numbers, types, sizes, etc.
- V – for: Vital equipment, a breakdown of which would mean an immediate and serious interruption of vital operations in field or plant and with which no risk in the ordering and stocking of spare parts can be justified.
- E – for: Essential equipment, engaged in primary operations, but with which a calculated risk can be taken in ordering and stocking of spare parts.
- A – for: Auxiliary, general purpose and stand-by equipment, for secondary operations, the temporary lack of spare parts would not have a serious effect.
- Under this heading also comes the equipment of which there is a large number of units in used, thus ensuring a sufficient degree of protection in case of failure of one or more units.

The Owner MESC project team should complete the following part of the SPIR form

- Col.16: For allocation of the final MESC number.
- Col.17: For the classification of spare parts, i.e.:
- C – for: Parts wearing out or deteriorating during normal operations, thus shown a fairly regular consumption.
- Q - for: Parts not normal stocked, but ordered on request only.
- I - for: Insurance items.
- O - for: Temporary code number.

THE VENDOR SHALL COMPLETE THE FOLLOWING PART OF THE SPIR FORM:

- Col.13: VENDOR'S recommended spare parts for 2 years operation.



National Petrochemical Company
Petrochemical Research & Technology Co.

PP-PE Pilot Plant



شرکت ملی صنایع پتروشیمی
شرکت پژوهش و فناوری پتروشیمی

Title: SPARE PARTS PROCEDURE

Page: 28

- Col.14: VENDOR'S recommended spare parts for the precommissioning, commissioning and start-up period.
- Col.22: This column has to be filled out for the respective parts purchase order-item reference. This number should be tagged to the respective material for easy identification upon receipt at site.
- Col.19: Total price (up to 2 decimals) of the spare parts for 2 years operation and the commissioning period based upon the quantities approved by the OWNER'S Project Engineer (see column 15)

NOTE: Columns 15, 17 and 21 should be left blank, these are for OWNER'S use.

THE OWNER'S PROJECT ENGINEER SHOULD COMPLETE THE FOLLOWING PART OF SPIR FORM:

- Col.15: Final quantity to be ordered and Approved by the OWNER's Project Engineer.
- Col.21: This column has to be used to indicate the equipment class, i.e.

IMPORTANT NOTE:

The necessary provisions shall be made to fix the prices of spare parts for all equipment and materials for future purchasing of the spare parts by OWNER more than which shall be purchased by VENDOR for two years operations of the PLANT all EQUIPMENT AND MATERIALS for future purchasing of the spare

ATTACHMENT 4

SPIR Form:

1	2	3	4	5	6	7	8	9	10	11	12	13	14	15	16	17	18	19	20	21	22	23	24	25	26			
EQUIPMENT REQ. OR TAG NO.	MANUFACT URE'S MODEL OR TYPE	MANUFACTURER'S SERIAL NO.	NO. OF UNITS	NO. OF PARTS PER UNIT	MISC NO. OF EQPT OR ORDER REF. NO.	DESCRIPTION OF PARTS	MATERIAL SPECIFICATION	MANUFACTURER'S ORIGIN NUMBER	MAKE OF THE SUPPLIER OR BRAND NAME	PART NUMBER REFER TO SHEET 3	MISC NUMBER	UNIT PRICE	COMMISSIONING RECOMMENDED BY MANUFACTURER	COMMISSIONING RECOMMENDED BY LICENSOR	PHYSICAL STOCK	QUANTITY TO BE ORDERED	SPARE PARTS LIST AND INTERCHANGEABILITY RECORD	SPARE NUMBER:	GROUP:	APPROVED FOR PURCHASE BY:	REQUIRED ON SITE DATE:	DELIVERY TIME BY WEEKS	COMMISSIONING ACTUAL (1 YEAR)	COMMISSIONING ACTUAL (1 YEAR)	COMMISSIONING NORMAL (2 YEAR)	COMMISSIONING NORMAL (2 YEAR)	CRITICAL	
P-YYYYAB	XXX	XXXXXXXX	2	1		Ball Bearing	AC26 E200	NSK	#729BGF	PC																		
P-XXXA/B/C	XXX	XXXXXXXX	2	2		O-Ring	NSR			PC																		

SPARE PARTS LIST AND INTERCHANGEABILITY RECORD

NOTE: (In case of sub-vendor's item, name of sub-vendor to be shown in the column of Manufacturer.)

NOTE: PLEASE REFER EXPLANATION OF THE COLUMNS ON SHEET 2 BEFORE FILLING UP THE FORM.

NOTE: (Unit of Qty of parts to be shown.)

NOTE: (The list with "Currency Unit", "Validity Date", "Unit Price", and "Delivery Time" to be sent by excel file via Email separately.)

NOTE: (The list without "Currency Unit", "Validity Date", "Unit Price", and "Delivery Time" to be submitted with cover page as the drawing.)

NOTE: (Qty of spare parts recommended by Vendor to be shown.)

NOTE: (Delivery time (Business) to be shown.)

NOTE: (Unit price including seasonality report pending to be shown.)